



# Tool Bar Mount Kit Assembly AU-9007

Go to [www.tilmor.com/resources](http://www.tilmor.com/resources) for complete parts list, additional resources and replacement part ordering.

Release Date: 05/24/2019  
Document Number: 12-70023  
Revision Number: 00

**ATTENTION**  
Review safety information before operation.

Tools	
	9/16" Socket Torque Wrench

**Installation Time (estimated)** 15 minutes

## REQUIRED PARTS

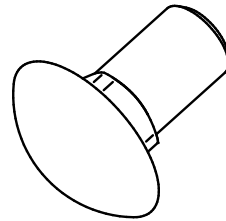
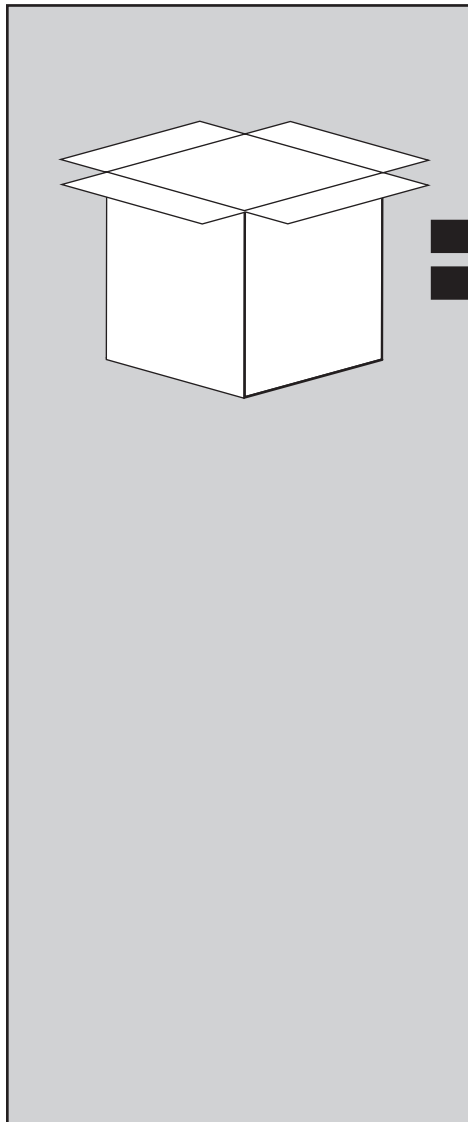

4x Bolt, Carriage  
3/8" x 1"  
97-0608

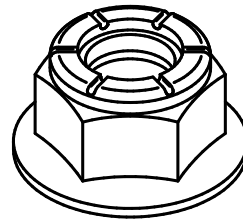

8x Nut, Locking  
Flange 3/8"  
99-E0136

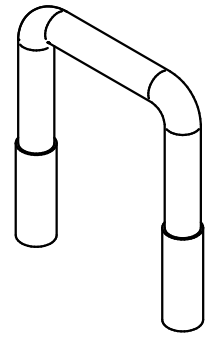

2x U-Bolt, SQ 3/8 X 1 X 2"  
11-0088

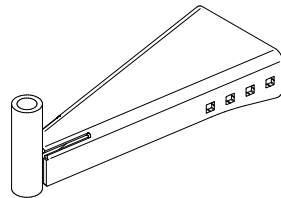

1x Toolbar Mount Frame  
AU-6005

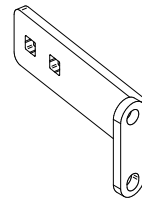

2x Toolbar Mount Bracket  
AU-1072

# ASSEMBLY

 9/16" Socket, Torque Wrench

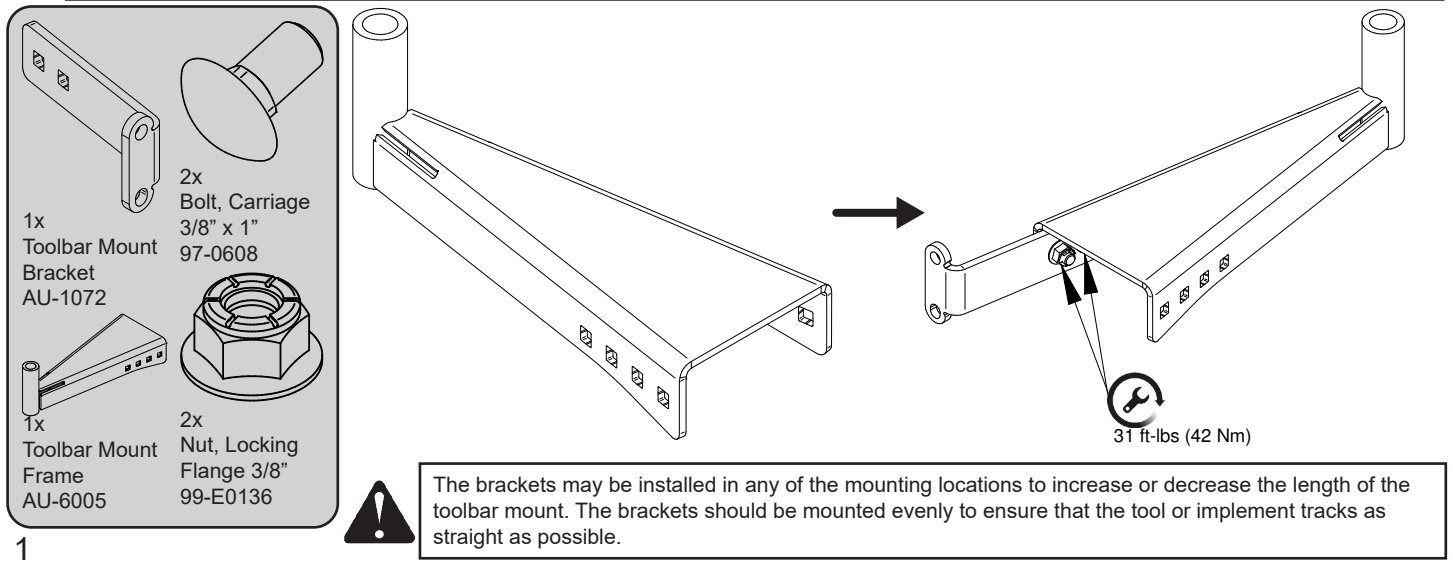

1x  
Toolbar Mount  
Bracket  
AU-1072

2x  
Bolt, Carriage  
3/8" x 1"  
97-0608

1x  
Toolbar Mount  
Frame  
AU-6005

2x  
Nut, Locking  
Flange 3/8"  
99-E0136

31 ft-lbs (42 Nm)

 The brackets may be installed in any of the mounting locations to increase or decrease the length of the toolbar mount. The brackets should be mounted evenly to ensure that the tool or implement tracks as straight as possible.

1

 9/16" Socket, Torque Wrench

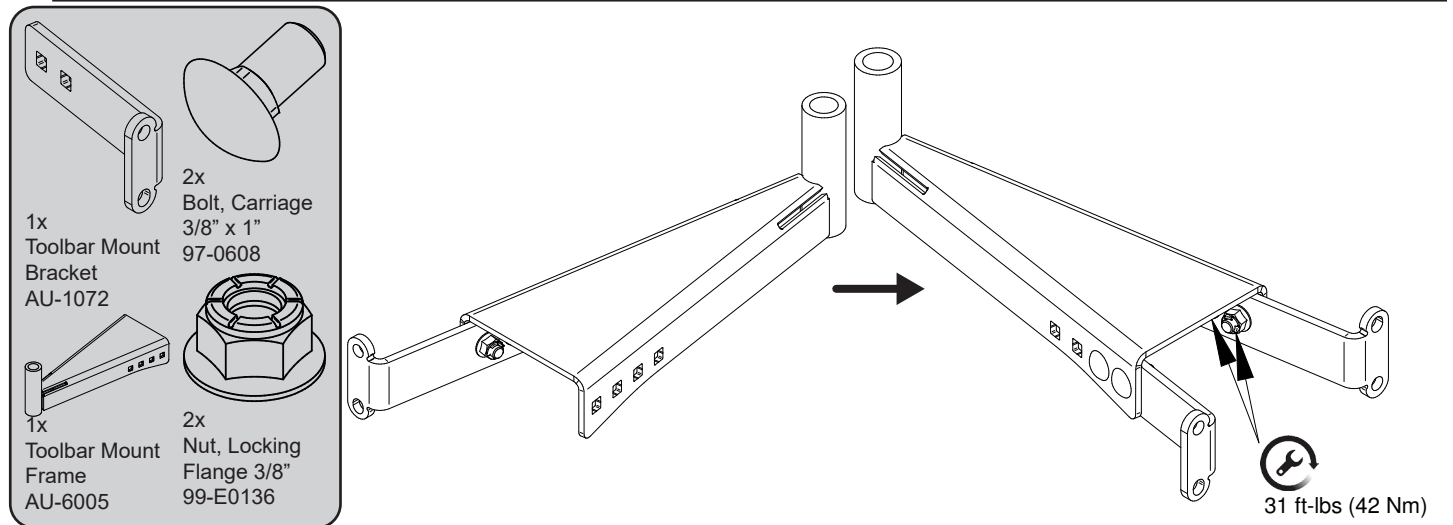

1x  
Toolbar Mount  
Bracket  
AU-1072

2x  
Bolt, Carriage  
3/8" x 1"  
97-0608

1x  
Toolbar Mount  
Frame  
AU-6005

2x  
Nut, Locking  
Flange 3/8"  
99-E0136

31 ft-lbs (42 Nm)

2

 9/16" Socket, Torque Wrench

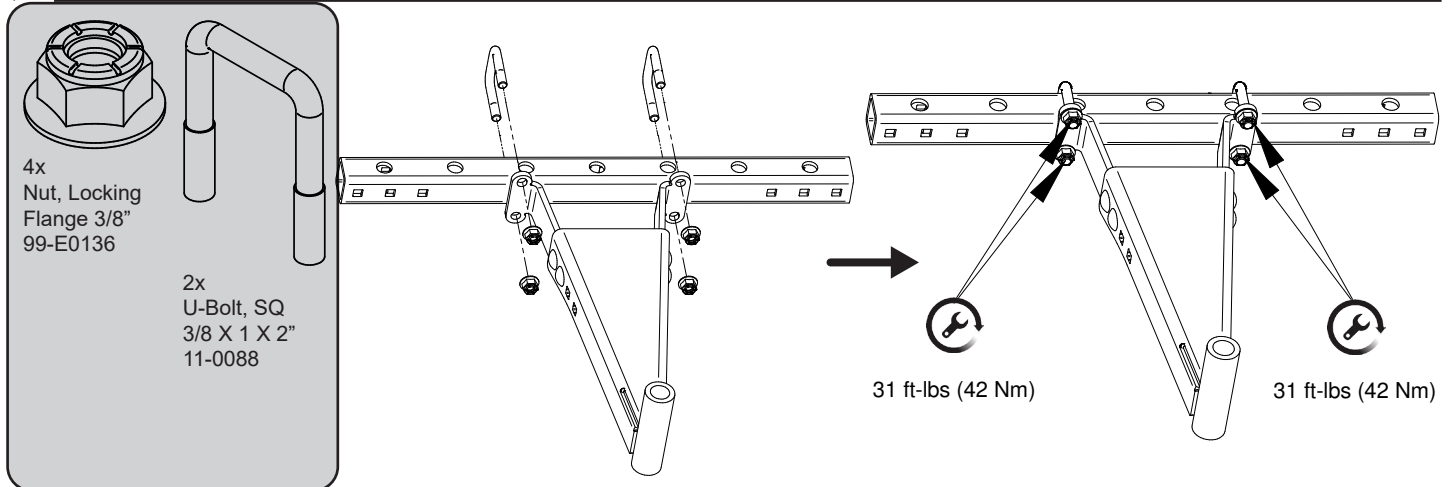

4x  
Nut, Locking  
Flange 3/8"  
99-E0136

2x  
U-Bolt, SQ  
3/8 X 1 X 2"  
11-0088

31 ft-lbs (42 Nm)

31 ft-lbs (42 Nm)

3