

SCREW DEPTH ADJUSTMENT - SCREW DEPTH ADJUSTMENT

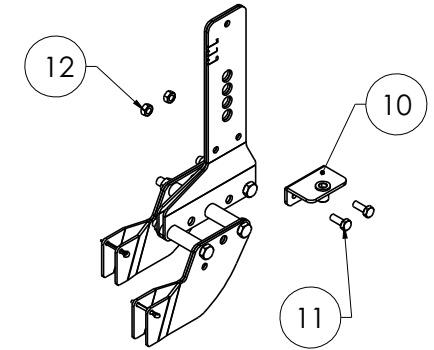



R3 SEEDS - 3 SOWING LINES AT 4.5 cm - W5

100-00-VVV-00035-37

Rev. 00

REF.	Q.TY	DESCRIPTION	CODE
1	1	MONT. R3 SAW	100-00-A0R-00003
2	1	PLUG LATCH	100-00-P0B-00099
3	1	PA11 PIPE Øe14 Øi10 L=193	100-00-P0B-00307
4	1	PA11 PIPE Øe14 Øi10 L=195	100-00-P0B-00308
5	1	ELASTIC PIN Ø2x50 UNI 8833-A	999-00-C0S-00002
6	1	MONT. COVER R2-R3	AS-00015
7	1	R2-R3 SEMI LOWER GUIDE ASSEMBLY	AS-00030
8	1	R2-R3 SELECTOR	PL-00041
9	1	PA11 PIPE Øe14 Øi10 L=185	100-00-P0B-00305
SCREW DEPTH ADJUSTMENT - SCREW DEPTH ADJUSTMENT			
10	1	LAM. REG. SCREW WITH INSERT	100-00-P0C-00110
11	2	TE SCREW M6x16 - 8.8 ZN UNI 5739	999-00-C0A-20616
12	2	HEXAGONAL NUT M6 ZN UNI 5588	999-00-C0B-10006

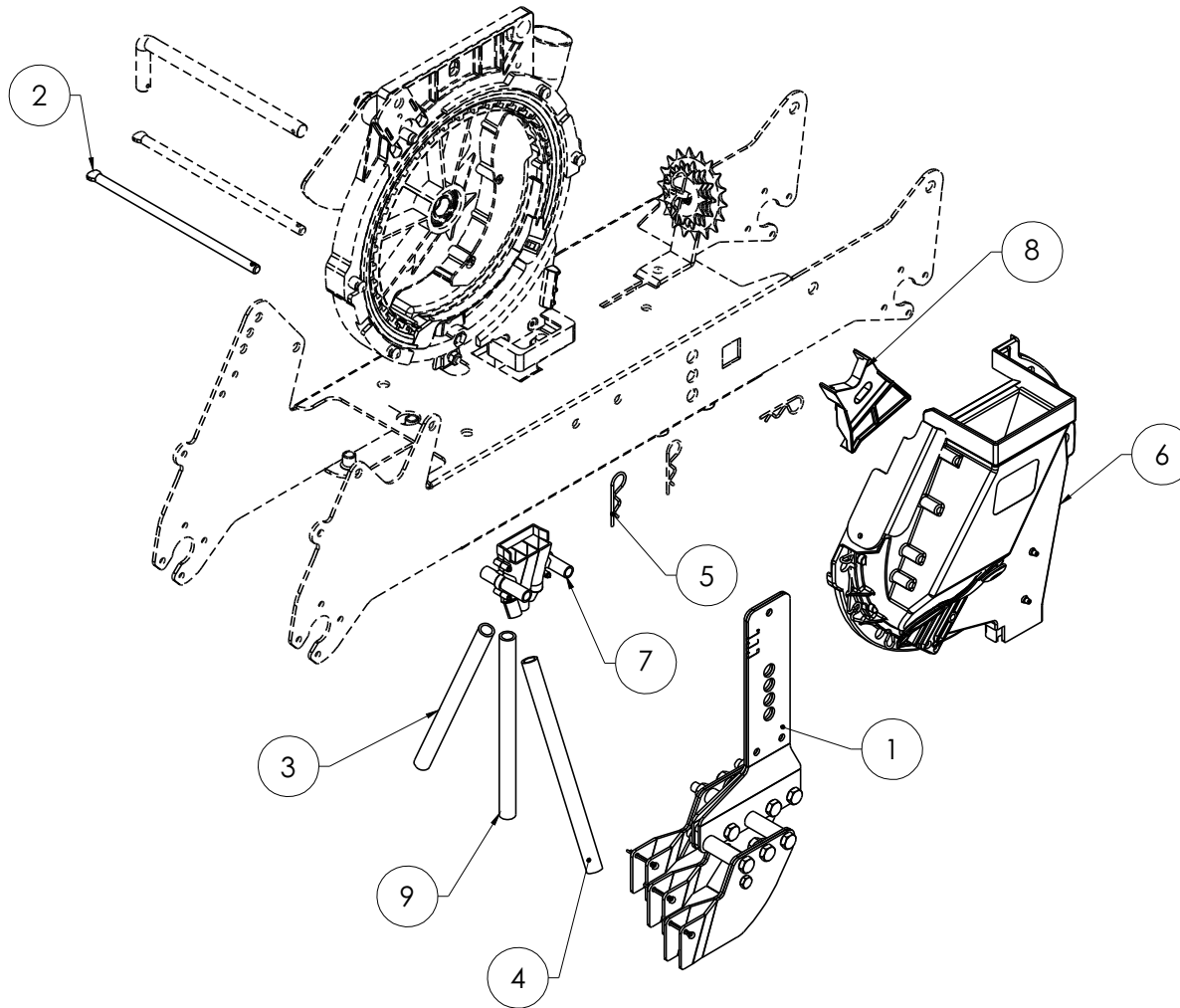

REGOLAZIONE PROFONDITA' A VITE - SCREW DEPTH ADJUSTMENT

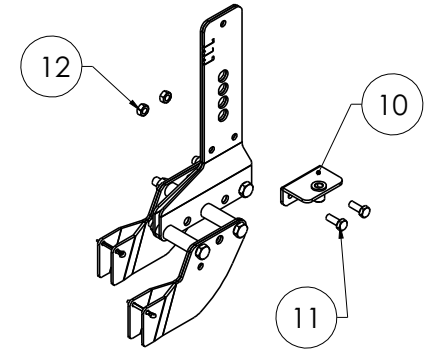



R3 SEMI MINUTI - 3 LINEE DI SEMINA A 4,5 cm - W5

100-00-VVV-00035-37 Rev. 00

RIF.	Q.TA'	DESCRIZIONE	CODICE
1	1	MONT. FALCIONE R3	100-00-A0R-00003
2	1	SPINA CHIAVISTELLO	100-00-P0B-00099
3	1	TUBO PA11 Øe14 Øi10 L=193	100-00-P0B-00307
4	1	TUBO PA11 Øe14 Øi10 L=195	100-00-P0B-00308
5	1	COPIGLIA ELASTICA Ø2x50 UNI 8833-A	999-00-C0S-00002
6	1	MONT. COPERCHIO R2-R3	AS-00015
7	1	MONTAGGIO GUIDA SEMI INFERIORE R2-R3	AS-00030
8	1	SELETTORE R2-R3	PL-00041
9	1	TUBO PA11 Øe14 Øi10 L=185	100-00-P0B-00305
REGOLAZIONE PROFONDITA' A VITE - SCREW DEPTH ADJUSTMENT			
10	1	LAM. REG. A VITE CON INSERTO	100-00-P0C-00110
11	2	VITE TE M6x16 - 8.8 ZN UNI 5739	999-00-C0A-20616
12	2	DADO ESAGONALE M6 ZN UNI 5588	999-00-C0B-10006