



# Owner's Manual

## Model# PR2500 Plastic Mulch Lifter Wrapper

Dealer: _____
Contact: _____
Phone: _____
Model #: _____
Serial #: _____

Manufactured by PBZ LLC  
A Paul B Zimmerman Inc. Company  
[www.CropCareEquipment.com](http://www.CropCareEquipment.com)



Thank you for purchasing this CropCare® product. This owners manual contains helpful information regarding the installation, operation and maintenance of your product. For parts and service please contact your local CropCare® dealer.

## Table Of Contents

Before You Begin.....	4
Safety Precautions.....	4
General Guidelines.....	4
Before Operation .....	5
During Operation .....	5
Following Operation .....	6
Operating Instructions .....	6
Setting the Width .....	6
Setting the Depth.....	7
Preparing for Wrapping.....	8
Using the Control Levers.....	8
Plastic Wrapping .....	9
Removing the Plastic.....	9
Maintenance Instructions .....	9
Routine Maintenance.....	9
Adjusting the Reels.....	10
Hose Maintenance .....	10
CropCare® Limited Warranty .....	11
Contact Us.....	12
Ordering Parts.....	12

# Before You Begin

Please read and understand this manual and its instructions and warnings completely before operating equipment.

- Be aware of all safety guidelines, warnings, and cautions.
- Familiarize yourself and other operators with the plastic wrapper's components and how all parts are operated.
- Always remember that good safety practices are the most important part of operating a piece of equipment.

# Safety Precautions

## General Guidelines

Every year many unnecessary accidents occur due to improper equipment handling and a disregard for safety precautions. You, the operator, can avoid accidents by observing the precautions in this section.

- The operators of the tractor and the plastic wrapper should be responsible adults. Do not allow persons to operate this machine until they have displayed a thorough understanding of the safety precautions and operational use!
- Never attempt to operate this machine while under the influence of alcohol or drugs.
- The best defense against accidents is a careful and responsible operator.
- Be aware of the location of all safety warning decals (Figures 1-4).
- When transporting the plastic wrapper on public roads, always follow state and local regulations regarding safety and transportation requirements. Use the necessary lights and slow moving vehicle (SMV) emblems.
- If there is any portion of this manual that you do not fully understand, please contact an authorized CropCare® dealer.



Figure 1: Read Owner's Manual Warning (DE115)



Figure 2: Moving Parts Warning (DE128)



Figure 3: Moving Parts Warning (DE127)



Figure 4: Operating Outside of Platform Warning (DE129)

# Safety Precautions



## Before Operation

- Carefully study and understand this owner's manual.
- Give the plastic wrapper a visual inspection for any worn parts, loose bolts, or other visible problems, and make any needed repairs. See the "Maintenance Instructions" section.
- Have all operators practice operating the plastic wrapper until all operators are completely capable of safe operation.
- Do not wear loose-fitting clothing which may catch in moving parts.
- Ensure that the plastic wrapper does not exceed the tractor's load rating. The plastic wrapper, when empty, weighs approximately 1000 lbs.
- Never check for hydraulic hose leaks with your hands! If oil penetrates the skin and enters the bloodstream, it could result in serious injury or death. If there is any visible damage to the hoses, replace them immediately.
- Make sure that the operating area is clear of any people or obstructions before using the plastic wrapper.
- Do not allow people near the plastic wrapper at any time during operation!
- Never allow personnel to ride on the operator's platform while the wrapper is in the raised position for transport!



## During Operation

- Always be aware of bystanders, particularly children! Never allow anyone, other than the operator, near the plastic wrapper when it is in operation or when the tractor is running.
- No passengers are allowed on or in the Plastic Lifter/Wrapper at any time.
- Be aware of the spinning reel which holds the plastic! Never allow anyone to adjust, clean, or be near the reels while the tractor is running! Keep all body parts, clothing, and tools (including the reel release bar) away from the reels during operation. Failure to follow these safety warnings could result in serious injury or death.
- Always turn the tractor off before removing plastic from the reels! Exercise caution when using the reel release bar due to the fact that the reel is under much tension.
- Never attempt to operate the plastic wrapper alone! One person must operate the tractor while another person operates the plastic wrapper.
- The plastic wrapper operator needs to follow special safety precautions. Never jump off of the plastic wrapper during operation! Always keep both hands on the grab rails. This practice will ensure stability in the case of sudden movements caused by uneven terrain.
- The operator of the tractor shouldn't routinely turn around to check the plastic wrapper. The tractor operator's main focus should be on driving. The plastic wrapper operator should signal verbally if the tractor operator should stop or adjust the speed.
- Never obstruct the movement of the control levers! The levers must be able to return to the neutral position when released.
- Never operate the tractor at speeds over 5 mph.
- Practice special caution when operating the plastic wrapper on uneven surfaces and on inclines. Do not attempt to operate the plastic wrapper on terrain that will, or could possibly, endanger the tractor or plastic wrapper operator! Be aware of dangerous terrain such as holes, slopes, drop-offs, banks, rocks, and hidden hazards.
- Remember that accidents can even happen to seasoned operators. Always take the necessary time and follow all safety instructions.
- Never leave running equipment unattended.
- Never allow personnel to ride on the operator's platform while the wrapper is in the raised position for transport!

# Safety Precautions



## Following Operation

- Following operation, stop the tractor unit, set the brakes, shut off the engine, and remove the ignition key.
- Before unhooking the plastic wrapper, lower the drop leg to provide stability.
- Park the plastic wrapper on a hard, level surface. Park the plastic wrapper indoors if at all possible.
- Store the plastic wrapper away from any human or livestock activity.
- Do not allow children to play on or around the plastic wrapper.

# Operating Instructions

Before operating the plastic wrapper, it is important to read the entire owner's manual and know all of the safety precautions. Always take the necessary time and be alert when operating the plastic wrapper. The simple actions will allow for continuous operation without accident or interruption.

NOTE: Remember to raise the drop leg (a), as shown (Figure 5), before operation!

NOTE: The example images in this section are shown with the sweep shovel and coil spring shank.

## Setting the Width

- Before setting the width, ensure that the plastic wrapper and all hydraulic hoses are properly connected.
- Adjust the shovel shanks so that the edge of the plastic (a) is 1"-2" from the inner side (b) of each shovel shank as shown (Figure 6).
- Position the side coulters (c), position them so that they are centered with the shovel shanks (b), as shown (Figure 6).

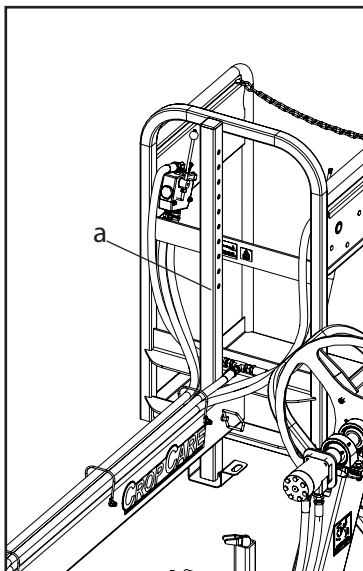

Figure 5: Drop leg

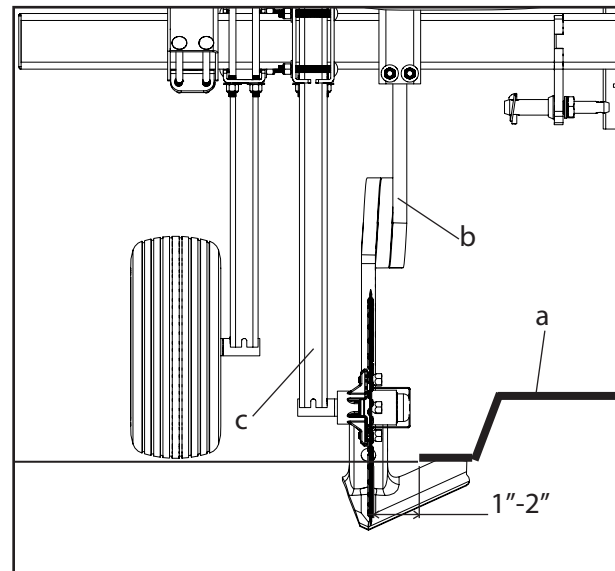

Figure 6: Settings the Width

# Operating Instructions

## Setting the Depth

The shovel shanks, gauge wheels, and side coulters will need to be adjusted to the correct depth. The depth adjustment will vary with the type of plastic rows (raised bed, flat bed) and with the amount of soil your plastic layer uses for coverage.

### Raised Bed

- The center coulter (a) should run about 2"-3" into the soil. It is important to note that the center coulter has only two settings and the higher setting is used for raised beds (Figure 7).
- Adjust the gauge wheels (c) to achieve the desired depth of the center coulter (a) and adjust the shovel shanks (d) and the side coulters (b) to proper depth (Figure 7).
- The wings on the shovel shanks should be set 1" below the plastic with the shank about 2" off of the outside edge of the plastic.
- The depth of the soil covering the plastic will vary with different plastic layers.
- Adjust the side coulters so that they run at approximately the same depth as the shovel on the shovel shank, and they are centered with the shovel shank as shown (Figure 6, Page 6).

### Flat Bed

- Set the center coulter (a) to the lowest setting. The center coulter should run about 2"-3" into the soil (Figure 7).
- Adjust the gauge wheels (c) to achieve the desired depth for the center coulter (a), then adjust the shovel shanks (d) and the side coulters (b) to the proper depth (Figure 7).
- The wings of the shovel shanks should be set 1" below the plastic with the shank 1"-2" off of the outside edge of the plastic.
- The depth of the soil covering the plastic will vary with different plastic layers.
- Adjust the side coulters so that they run at approximately the same depth as the shovel shank, and that they are centered with the shovel shank as shown (Figure 6, Page 6).

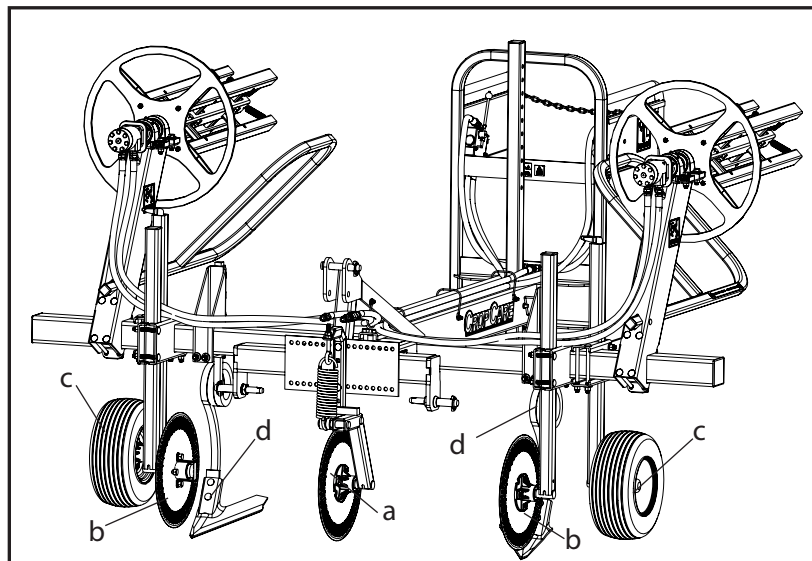

Figure 7: Setting the depth

# Operating Instructions

## Preparing for Wrapping

- It is very important for the tractor driver to keep the wrapper centered on the row.
- With the plastic wrapper set to the correct depth, drive 15 to 20 feet on the row to split and lift the plastic.
- Lift the end of the plastic and thread it through the plastic guide (a) and wrap it around the reel (b) as shown (Figure 8).
- Wrap the plastic around the reel and tie it to itself. (DO NOT tie the plastic directly to the reel as this will make removing the plastic difficult).
- Repeat the process for the other reel.

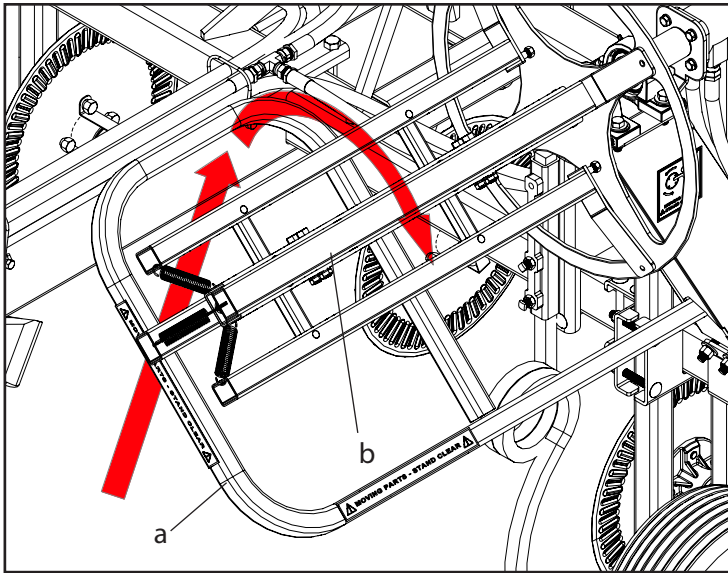

Figure 8: Preparing for wrapping

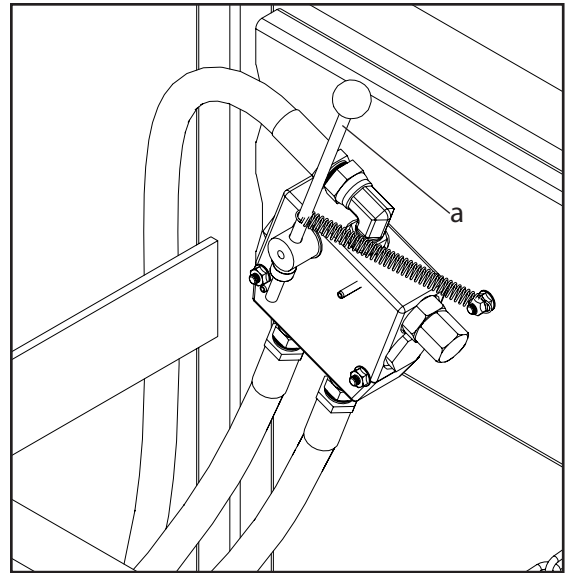

Figure 9: Control Lever

## Using the Control Levers

**WARNING:** Never operate the plastic reels while not standing on the operator's platform, or while a person is close to the reels

- The wrapper operator should stand on the wrapper platform and firmly grip the handrails at all times during operation.
- Be sure that the wrapper operator is familiar with the control levers before beginning operation.
- The control levers (a, Figure 9) control the speed at which the reels rotate. Pushing the levers forward will cause the reels to speed up, while pulling the levers back will cause the reels to slow down. The reels will stop when the levers are released.
- Before moving, push the levers forward to wrap up any excess plastic.
- When the tractor is in motion, the job of the wrapper operator is to control the speed of the reels. The reel speed must be adjusted to match the speed of travel.
- The plastic should be lifted approximately 6"-40" behind the coil shank.
- When the reels are spinning at the proper speed, the plastic should not touch the plastic guide (a, Figure 8).
- Note: Running the reel too slowly for an extended period of time will cause the plastic to wrap unevenly on the reel or fall off of the reel.



# Operating Instructions

## Plastic Wrapping

- While wrapping, the tractor driver should drive at a speed that is comfortable for the plastic wrapper operator.
- A comfortable speed may vary with the conditions, but generally 3-4 mph is recommended for safe and efficient operation.
- For plastic with heavy trash cover it may be necessary to slow down to give the trash time to fall away from the plastic.
- Operating the wrapper too slowly increases the chance of tearing the plastic.
- DO NOT operate the wrapper at speeds over 5 mph!
- The tractor driver should maintain a consistent travel speed and keep the machine centered on the row.
- NOTE: If equipped, there is a shear bolt (Figure 10) on the shovel shanks that will break (to prevent damage to the machine by allowing the shovel to “breakaway”) if there is an obstacle encountered that cannot be moved by the shovel.
- IMPORTANT: The shear bolt is a grade 8 bolt, and must be replaced with another grade 8 bolt if broken to ensure proper “breakaway” function of the shovel.

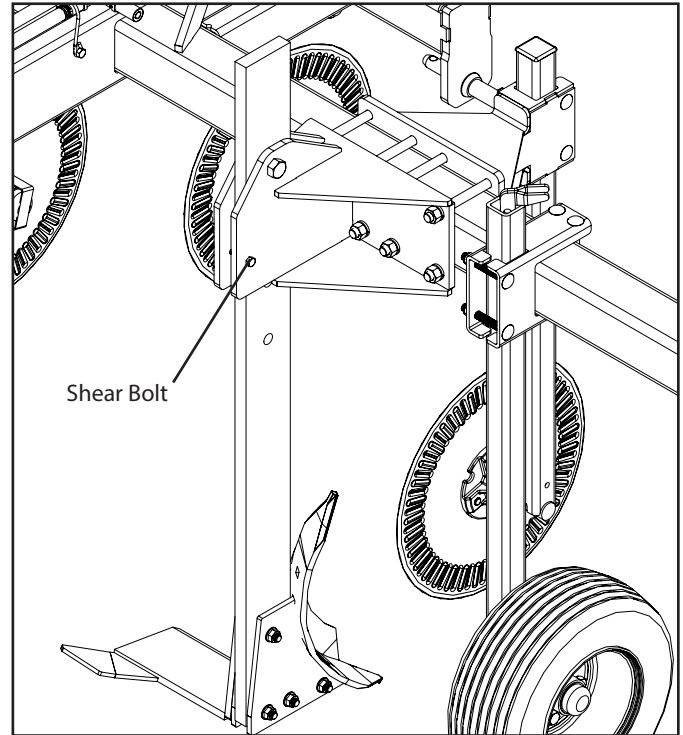

Figure 10: Shear Bolt

## Removing the Plastic

- When the reel is at, or near, capacity, it is necessary to remove the plastic from the reels.
- Turn the tractor off!
- With the tractor off, insert the reel release bar (a) into the reel and pull towards the front of the wrapper, as shown (Figure 11), to release and collapse the reel.
- Note: If it requires too much force to collapse the reel, the reel stops may need to be adjusted (see “Adjusting the Reel”, page 10).
- With the reels collapsed, the plastic should slide easily off of the reel.
- Before starting to wrap again, push the reel towards the front of the wrapper to ensure that it is firmly in the wrapping position so that the reel does not collapse during operation.

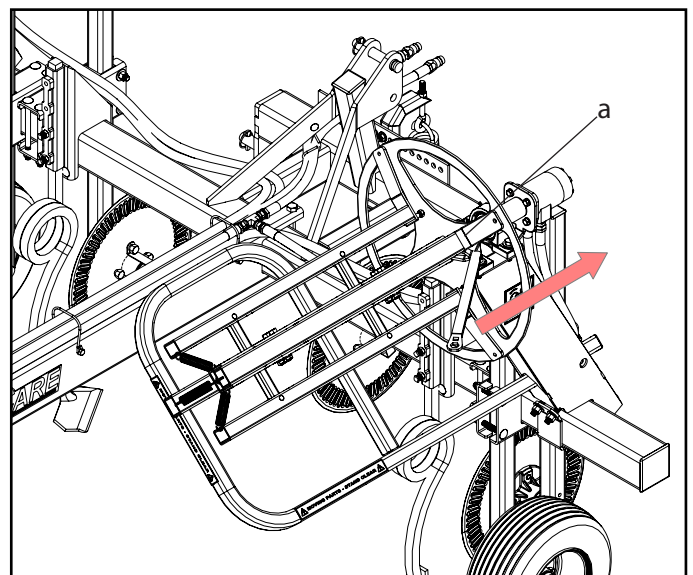

Figure 11 Removing the plastic

# Maintenance Instructions

## Routine Maintenance

It is very important to perform routine maintenance on your plastic wrapper before and after each use. Good maintenance practices will help to guard against any unnecessary machine breakdowns or accidents.

1. Perform a visual and physical inspection for worn parts, loose bolts, or other visible problems. Make all necessary repairs before operating. Contact an authorized CropCare® dealer for instructions on ordering parts and technical help.
2. The gauge wheels, center couler, and side couler hubs use sealed tapered bearings. Repack bearings with general purpose grease once per season.
3. The two shaft bearings (a) on each reel should be greased every 50 hours, or once per season of operation (Figure 11).
4. Lubricate the center couler pivot bushings with general purpose grease once per season.

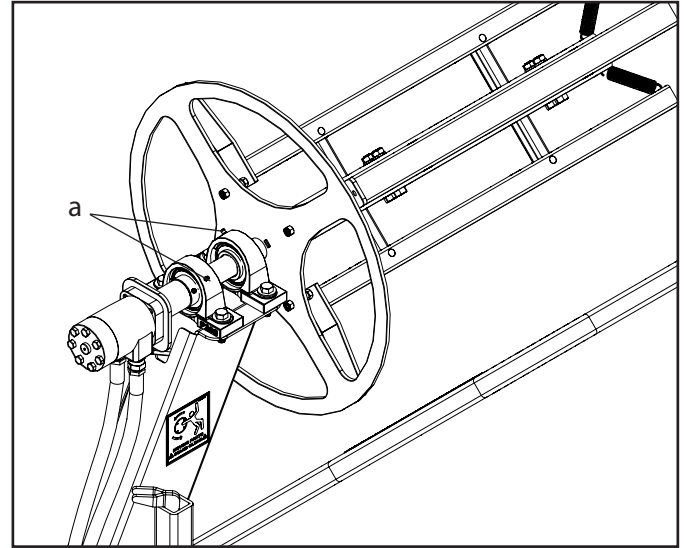

Figure 11: Shaft bearing grease zerks

## Adjusting the Reels

1. Over time, as the plastic wrapping reels wear, it may be necessary to adjust the stop bolts (a) on the reel bars (Figure 12).
2. When the stop bolts are adjusted properly the links (b) on the outer reel tubes should be tilted forward slightly and it should only take minimal force to release the reel (Figure 12).
3. If the links are tilted forward too far it will take excessive force to release the reel, which could result in damage to the reel. If the links are not tilted forward, the reel may collapse on its own during operation.
4. Adjust the nuts on the link stop bolts (a) to change the tilt of the links (b) (Figure 12).
5. The ends of the collapsible tubes (c) should extend 3-1/8" beyond the end of the center tube (d) (Figure 12).

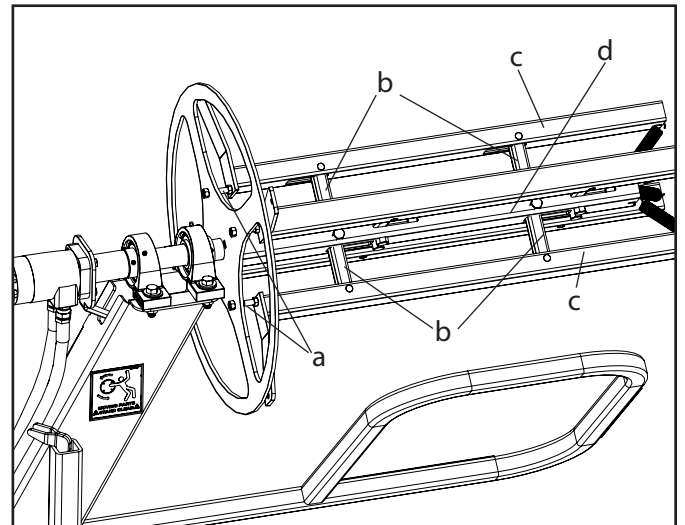

Figure 12: Adjusting the reel stop bolts

## Hose Maintenance

1. It is important to inspect the hydraulic hoses on the plastic wrapper before every use. Check the hoses for leaks and hose damage such as metal fibers showing.
2. **WARNING:** Never check for hydraulic hose leaks with your hands! If oil penetrates the skin and enters the bloodstream, the results can be fatal!
3. If there is any visible damage to the hoses, replace them immediately.

# CropCare<sup>®</sup> Limited Warranty

Plastic Lifter Wrapper, PR2500

## Warranty Coverage

CropCare<sup>®</sup> hereby provides a Limited Two (2) Year Warranty on the Products manufactured by CropCare<sup>®</sup> that such Products shall be free from manufacturer's defects in any of the Product's components in the 24 month period following the original date of purchase from the authorized dealer (the "Warranty Period"). CROPCARE<sup>®</sup> HEREBY EXCLUDES AND DISCLAIMS ANY AND ALL OTHER WARRANTIES, STATUTORY, EXPRESS OR IMPLIED, INCLUDING WITHOUT LIMITATION ANY IMPLIED WARRANTY OF MERCHANTABILITY OR FITNESS FOR ANY PARTICULAR PURPOSE AND ANY WARRANTY ARISING FROM USAGE OF TRADE OR COURSE OF DEALING. Defective components will be repaired or replaced at the discretion of the manufacturer. It is the responsibility of the purchaser to return warranted components to the manufacturer. This Product Warranty is limited to the repair or replacement of Product components only. CROPCARE<sup>®</sup> IS NOT TO BE HELD LIABLE FOR INCIDENTAL OR CONSEQUENTIAL DAMAGES OF ANY KIND. This Product Warranty covers the purchaser of this Product and any other owners who own it during Warranty Period.

To retain the Product Warranty, the Product must be operated and maintained as set forth by its owner's manual. For warranty service, please have a copy of the purchase invoice available.

## Warranty Is Void if:

1. The Product has been subjected to, in the opinion of CropCare<sup>®</sup>, negligent handling, misuse, an accident or if the instructions in the owner's manual were not completely followed.
2. The Product's components have been altered in any manner or repairs have taken place with unapproved parts.
3. The Product and its components were subject to freezing or freezing conditions. The Product must have been winterized as per the maintenance instructions to retain the Product Warranty.
4. A non-compatible chemical was used and/or if the Product operator failed to rinse all chemical residue out of the Product's components after use.
5. A petroleum-based, oil-based, or flammable product was used and caused damage to the pump, tank, hoses, or any other component.

## Getting Service

All Product Warranty claims must be made through an authorized CropCare<sup>®</sup> dealer. All warranty claims must be submitted with an invoice or a proof of purchase that denotes the purchase date and place of purchase. If you have any questions or comments concerning this warranty, please contact an authorized CropCare<sup>®</sup> dealer.

# Contact Us

We desire to give you continuing service in the best manner possible. This includes listening to your comments, suggestions, and problems. We will do our best to answer all questions thoroughly and in a timely manner. Please feel free to contact our customer service department.

## Ordering Parts

Please contact your authorized CropCare® dealer to order replacement parts for your product.

# **CROPCARE**

Manufactured by PBZ LLC  
A Paul B Zimmerman Inc. Company

295 Wood Corner Road  
Lititz PA 17543  
(717) 738-7365  
Fax (717) 738-7375  
[www.CropCareEquipment.com](http://www.CropCareEquipment.com)