

- 1 - 9/16" Wrench
- 1 - 5/8" Wrench
- 1 - 5/8" Socket and ratchet w/ extension

ITEM NO.	QTY.	DESCRIPTION	PART NUMBER
1	1	WORK BENCH BOTTOM (48X32)	79059611_00
2	4	CASTER (6X2 swivel, 1000lbs cap. total lock)	28522564
3	16	3/8-16X1 CARRIAGE BOLT 5 ZP	20603113
4	16	3/8-16 HEX SERRATED FLANGE NUT 2 ZP	24923960

Step 1

1. Install Caster (2) using Bolt (3) and Nut (4)

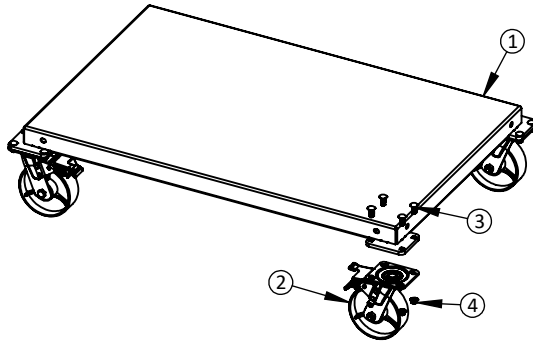

ITEM NO.	QTY.	DESCRIPTION	PART NUMBER
1	2	WORK BENCH SIDE (96X32 & 48X32)	79059632_00
2	8	7/16-14X1-1/4 CARRIAGE BOLT 5 ZP	20604120
3	8	7/16-14 HEX SERRATED FLANGE NUT 2 ZP	24924960

Step 2

1. Install Side (1) using Bolt (2) and Nut (3)

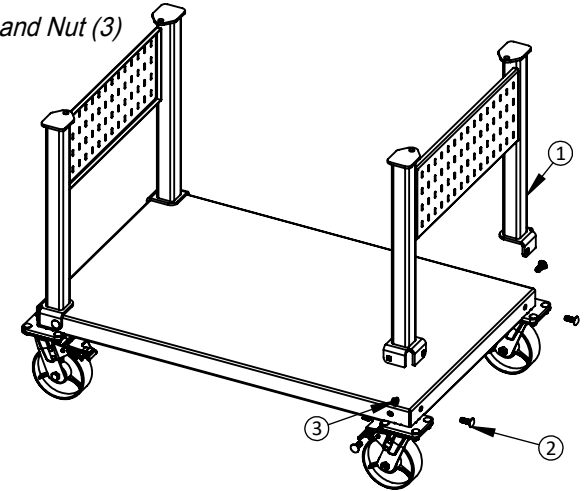

ITEM NO.	QTY.	DESCRIPTION	PART NUMBER
1	1	WORK BENCH TOP (48X32)	79059612_00
2	4	7/16-14X1-1/4 CARRIAGE BOLT 5 ZP	20604120
3	4	7/16-14 HEX SERRATED FLANGE NUT 2 ZP	24924960

Step 3

1. Install Top (1) using Bolt (2) and Nut (3)

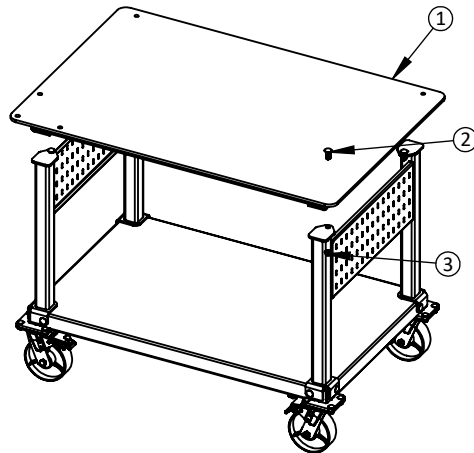

Step 4

1. Spray complete surface of top with WD40, Then use towel and wipe off rust inhibitor

