

78909100\_00

### WELD TABLE CART (48X30 mobile)

2 - 1/2" Wrenches

2 - 3/4" Wrenches

ITEM NO.	QTY.	DESCRIPTION	PART NUMBER
1	1	BOTTOM SHELF (welder cart)	78909103_00
2	2	CASTER (6X2 BLACK, SWIVEL W BRAKE, 800LBS)	28522553
3	2	CASTER (6X2 BLACK, RIGID, 800LBS)	28522550
4	16	5/16-18X3/4 FLANGE BOLT SERRATED GR5 BLACK ZP	20702080
5	16	5/16-18 HEX SERRATED FLANGE NUT 2 ZP BLACK	24922965

### Step 1

1. Install casters (2) & (3) to Bottom Shelf (1) using Bolt (4) and Nut (5)

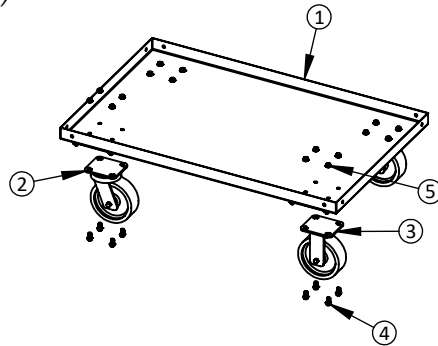

ITEM NO.	QTY.	DESCRIPTION	PART NUMBER
1	4	LEG (welder cart)	78909102_00
2	4	LEVEL MOUNT (1/2-13 w/ threaded stud, steel base)	24478345
3	8	5/16-18X3/4 FLANGE BOLT SERRATED GR5 BLACK ZP	20702080
4	8	5/16-18 HEX SERRATED FLANGE NUT 2 ZP BLACK	24922965

### Step 2

1. Install Level Mounts (2) to Legs (1)
2. Install Legs to Bottom Shelf using Bolt (3) and Nut (4)

#### Note:

Finger tighten nuts only

#### Note:

Make sure Legs with decal get installed at these corners

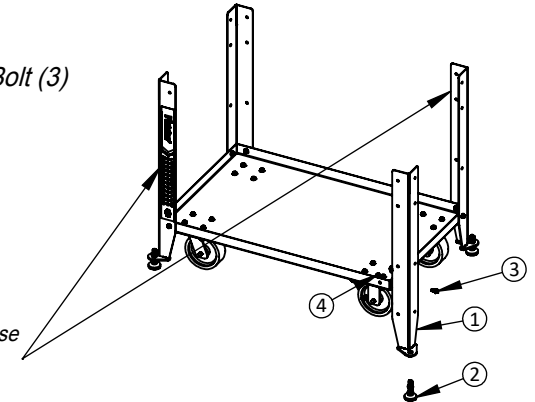

ITEM NO.	QTY.	DESCRIPTION	PART NUMBER
1	2	GRIDLOK PANEL (welder cart)	470605415_00
2	8	5/16-18X3/4 FLANGE BOLT SERRATED GR5 BLACK ZP	20702080
3	8	5/16-18 HEX SERRATED FLANGE NUT 2 ZP BLACK	24922965

### Step 3

1. Install Gridlok Panel (1) using bolt (2) and Nut (3)

#### Note:

Finger tighten nuts only

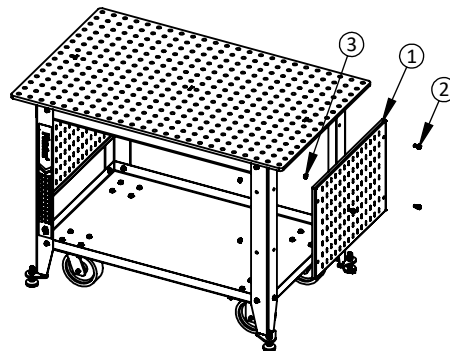

ITEM NO.	QTY.	DESCRIPTION	PART NUMBER
1	1	WELD TABLE TOP (48X30)	78909101_00
2	8	5/16-18X3/4 FLANGE BOLT SERRATED GR5 BLACK ZP	20702080
3	8	5/16-18 HEX SERRATED FLANGE NUT 2 ZP BLACK	24922965

### Step 4

1. Install Top (1) using Bolt (2) and Nut (3)

#### Note:

Tighten all nuts

