

Go to www.tilmor.com/resources for complete parts list, additional resources and replacement part ordering.

⚠ ATTENTION
Review safety information before operation.





Tools	
Required:	
9/16" Wrench	
1/2" Wrench	
Tape or Marker	
Measuring Tape	
5/16" Allen Wrench	
Needle Nose Pliers	
Recommended:	
Impact Wrench	
Swivel Socket Set or Universal Joint	
Socket extensions	

FRAME ASSEMBLY

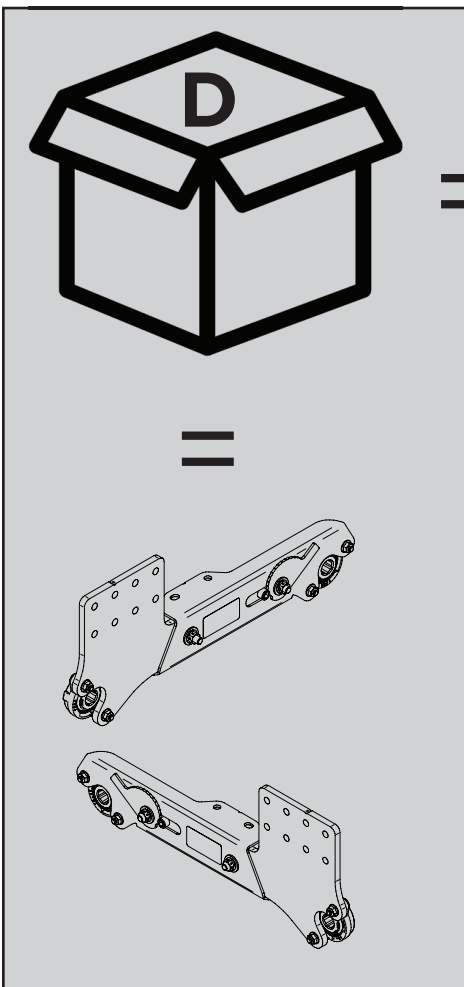

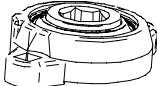
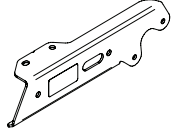
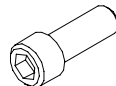
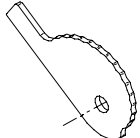
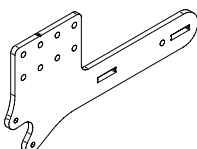
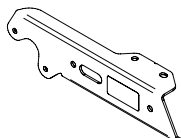
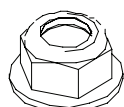
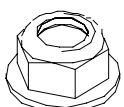
9/16" AND 1/2" WRENCH OR SOCKET

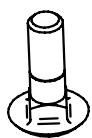
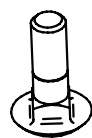
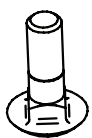
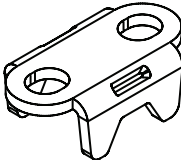
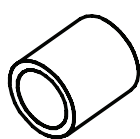

- | | | | |
|--|--|--|--|
| 
4x
55.FB16012-H | 
1x
AW-1036 | 
2x
99.K0151
Cap Screw | 
2x
AW-1055 |
| 
2x
AW-1038 | 
1x
AW-1037 | 
8x
99.E0102
5/16-18 Locking Flange | 
18x
99.E0082
3/8-16 Locking Flange |
| 
2x
11.0082
U-Bolt 3/8-16 x 1 | 
4x
97.0510
Carriage Bolt 5/16-18 x 1 1/4 | 
12x
97.0610
Carriage Bolt 3/8-16 x 1 1/4 | 
4x
97.0508
Carriage Bolt 5/16-18 x 1 |
| 
2x
AW-1083 | 
1x
AW-1085
1.375" - Long | 
1x
AW-1093
.625" - Short | 
2x
AW-1086
1" |



Qty. 8 of 97.0610 and Qty. 8 of 99.E0082 will be saved and used during the "Mount Installation" step.

FRAME ASSEMBLY (LEFT SIDE)



9/16" AND 1/2" WRENCH OR SOCKET

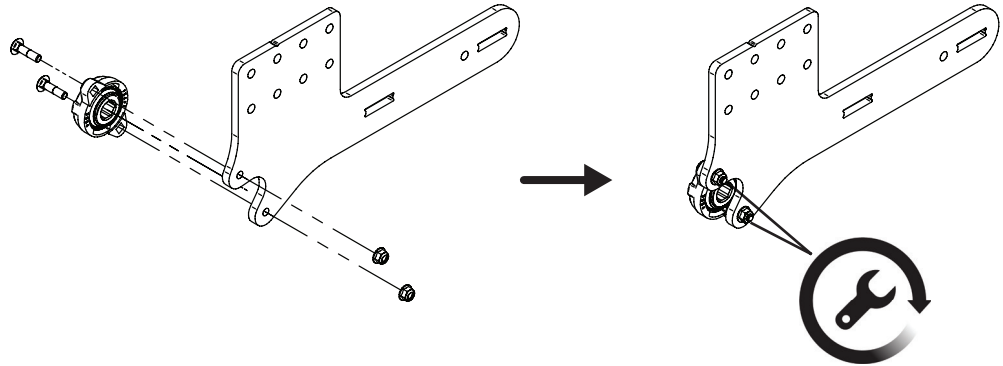
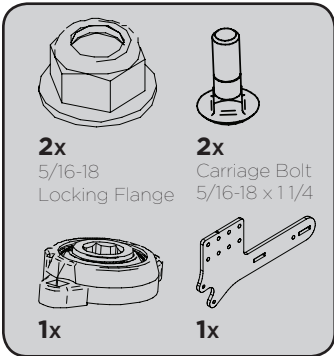

1

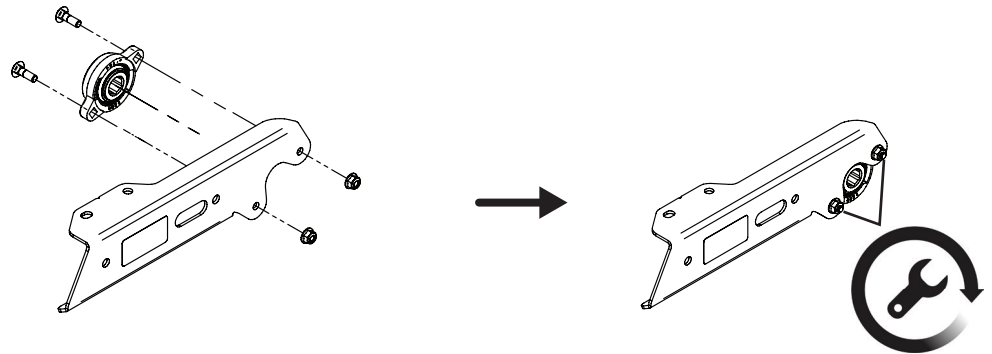
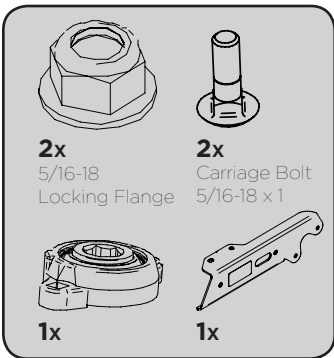

2

3

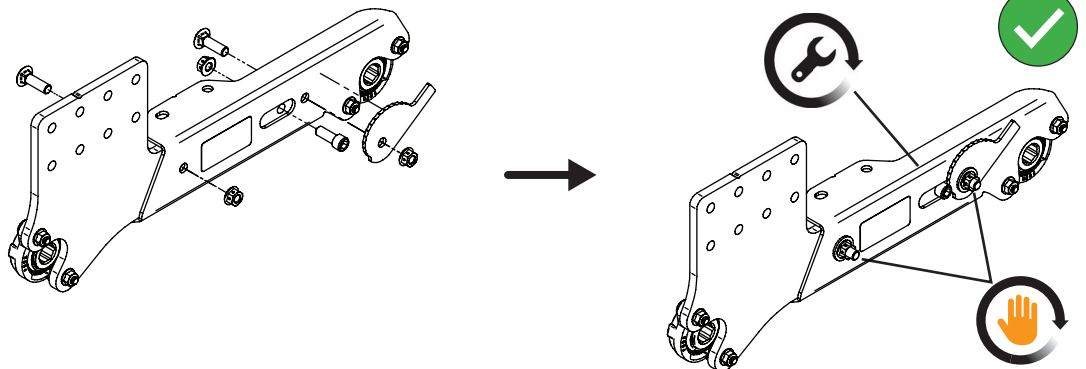
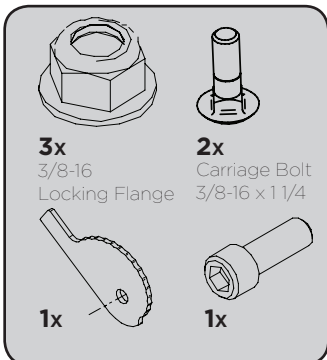
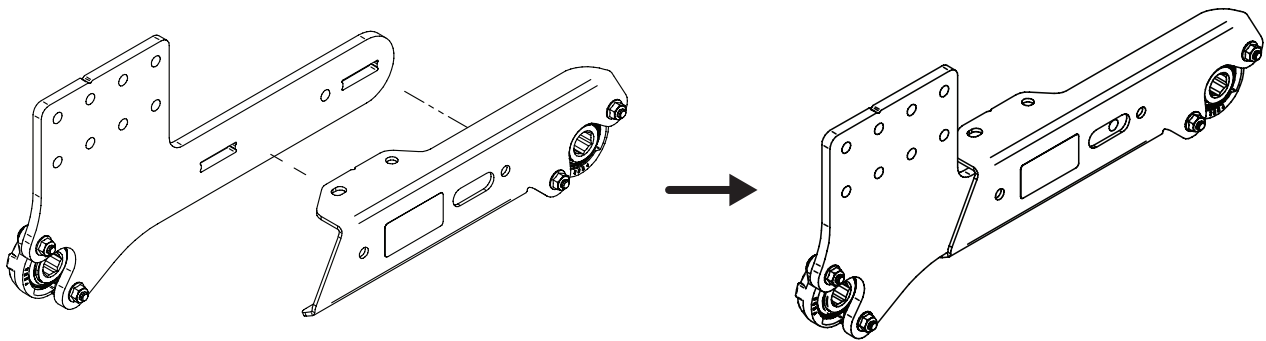

4

FRAME ASSEMBLY (RIGHT SIDE)



9/16" AND 1/2" WRENCH OR SOCKET

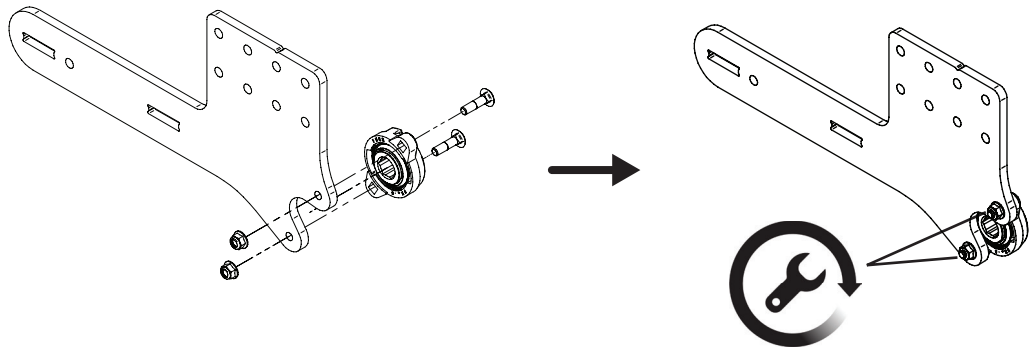
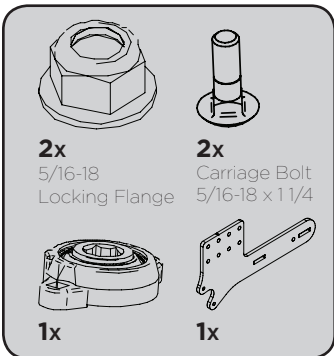

1

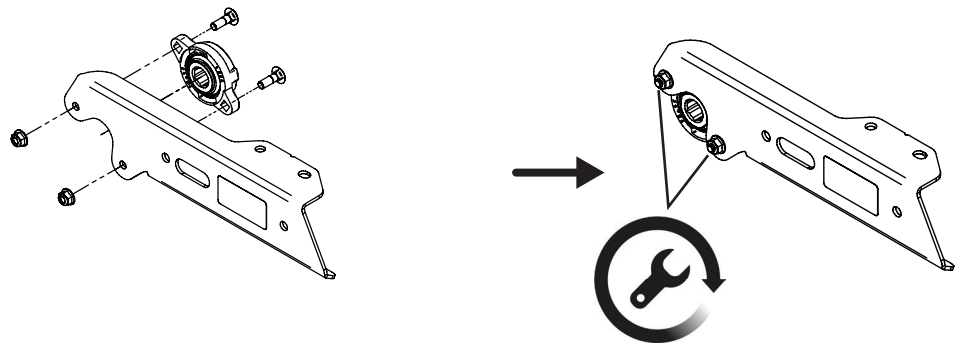
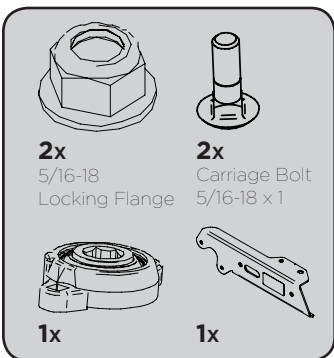

2

3

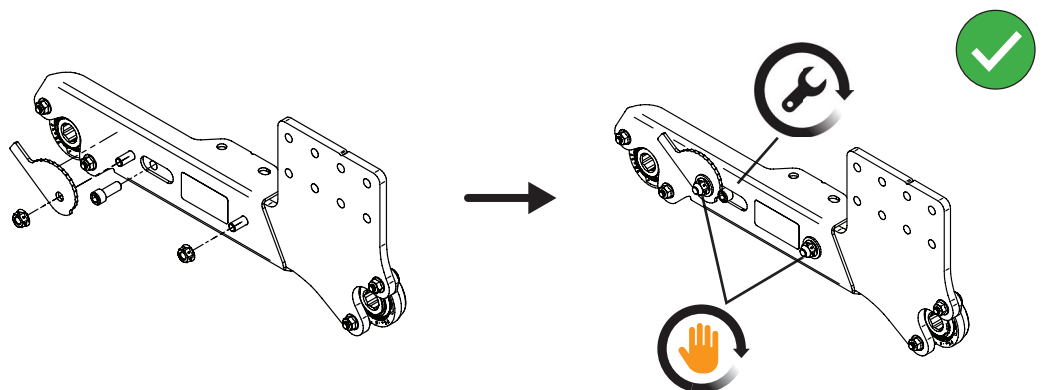
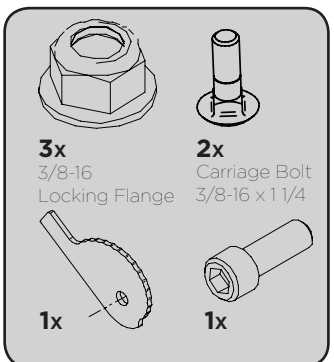
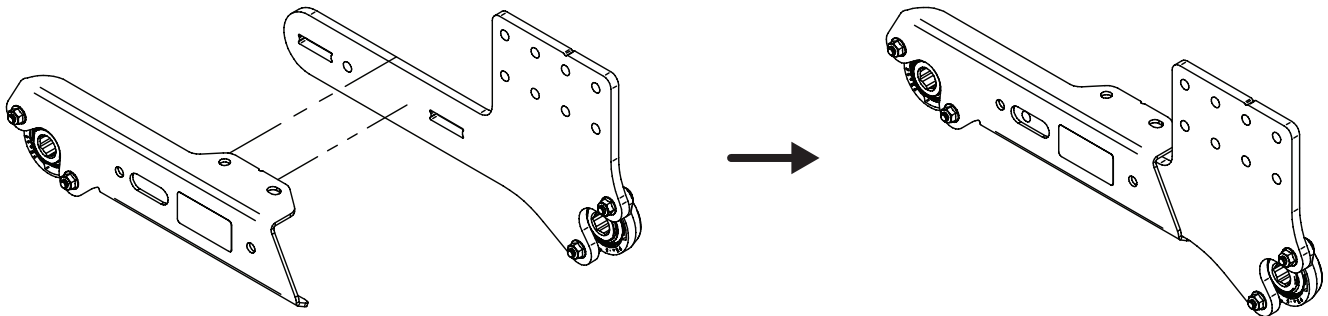

4

BASKET ASSEMBLY (PER BASKET)



9/16" WRENCH OR SOCKET

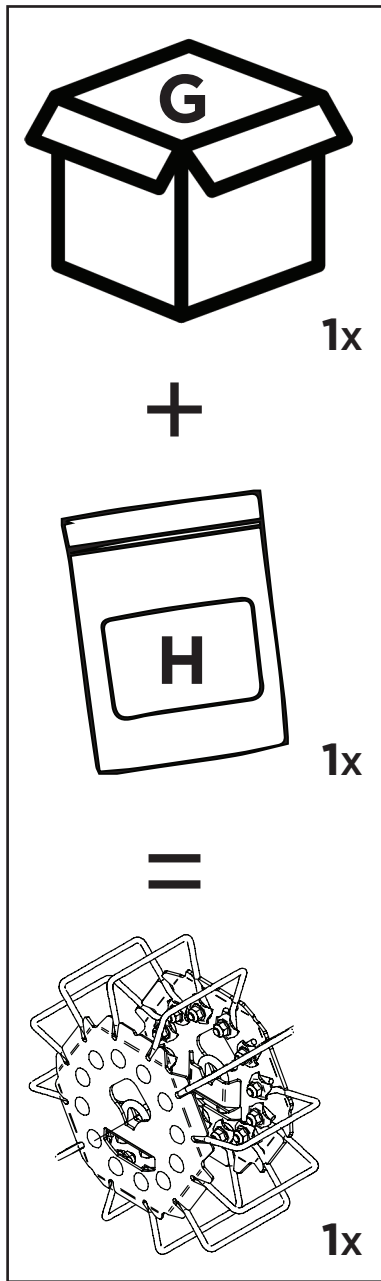

=



24x
AW-3003

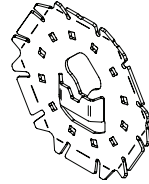

2x
AW-6009

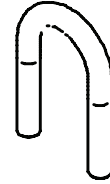

2x
11.0087

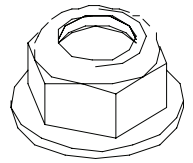

28x
99.SF06

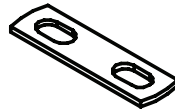

2x
AW-3021

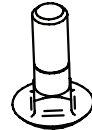

24x
97.0608

=

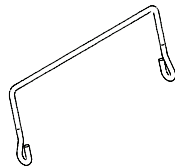

12x
AW-30__

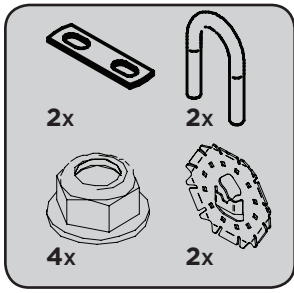

1

x2

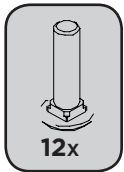
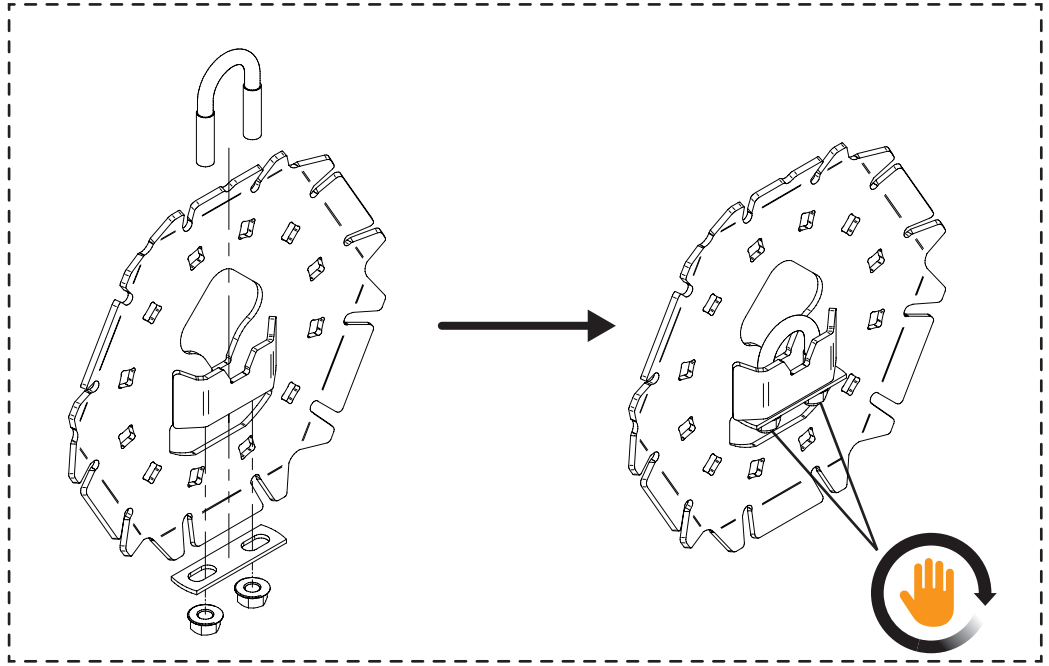

2

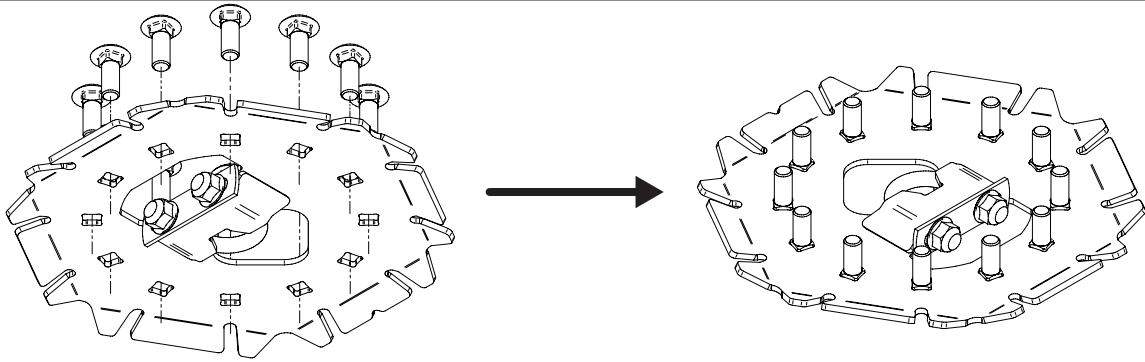

Tip: Put all bolts in from the top and use a piece of wood/metal/cardboard to flip everything over to prevent bolts from falling out.

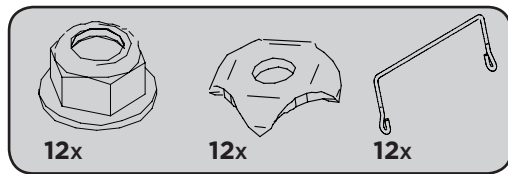

3

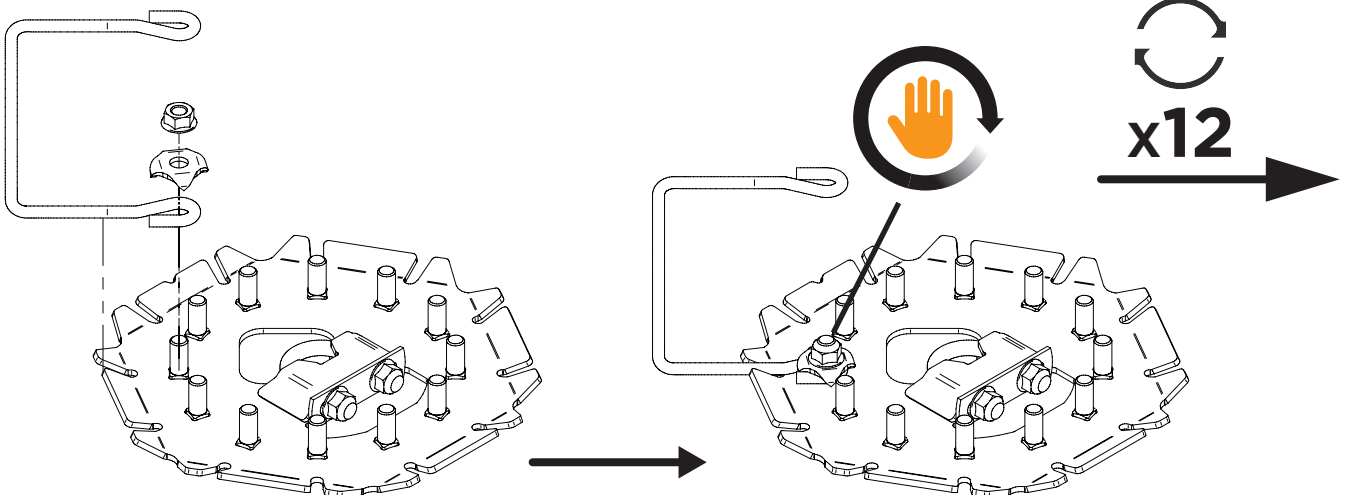

3 CONT'D

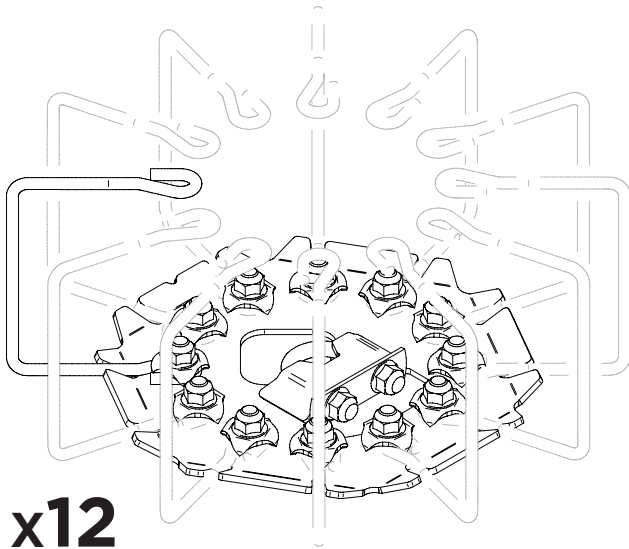

x12

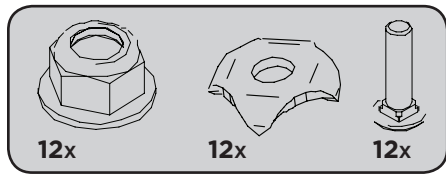
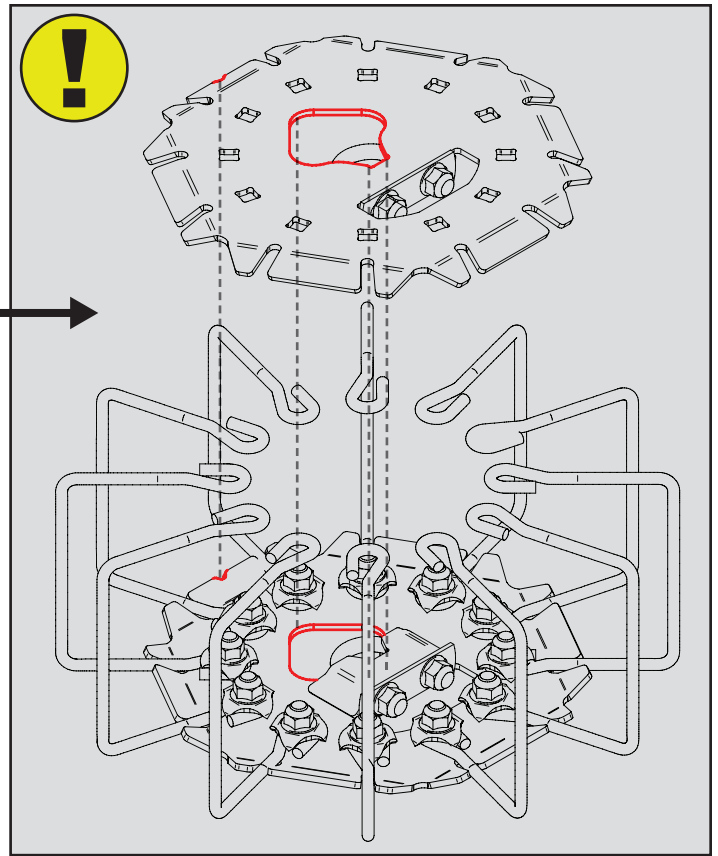

4

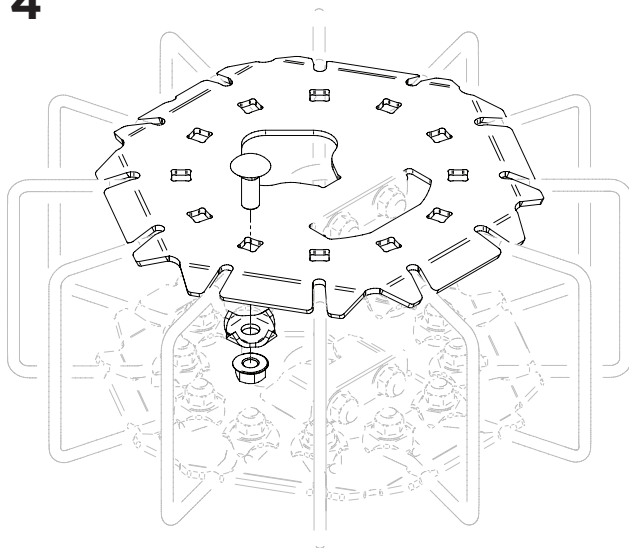

x24

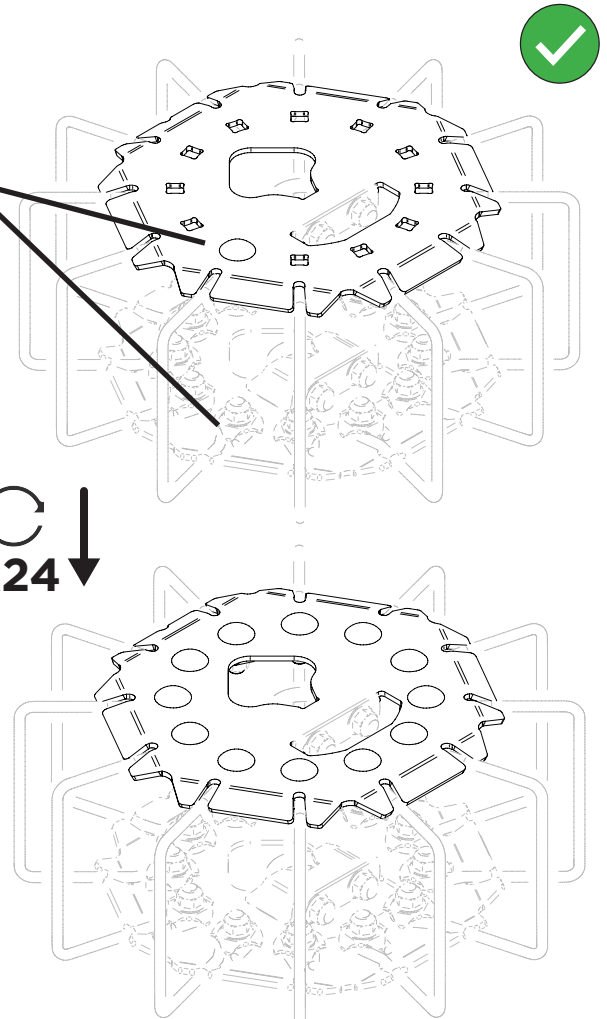

INSTALLING BASKETS ON HEX SHAFTS



9/16" WRENCH OR SOCKET

TAPE OR MARKER

MEASURING TAPE

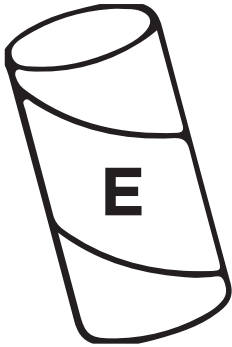

=

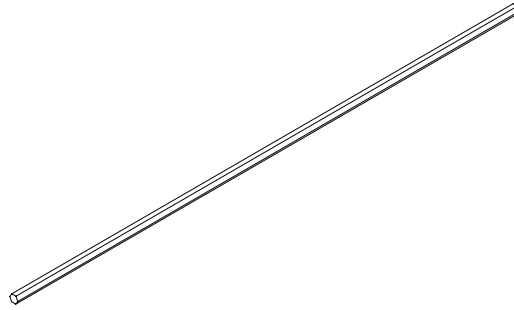

2x
AW-302_

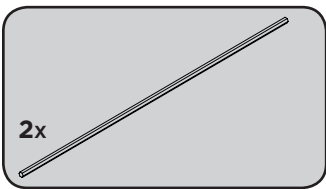

1

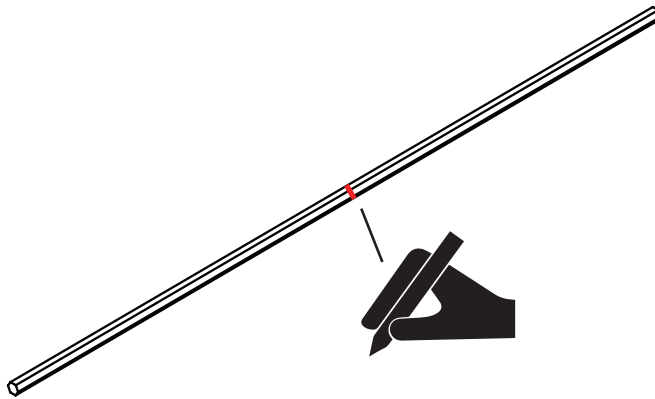

Measure and mark the center of each axle with a marker or piece of tape.

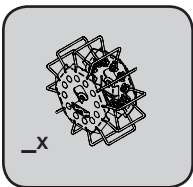

2

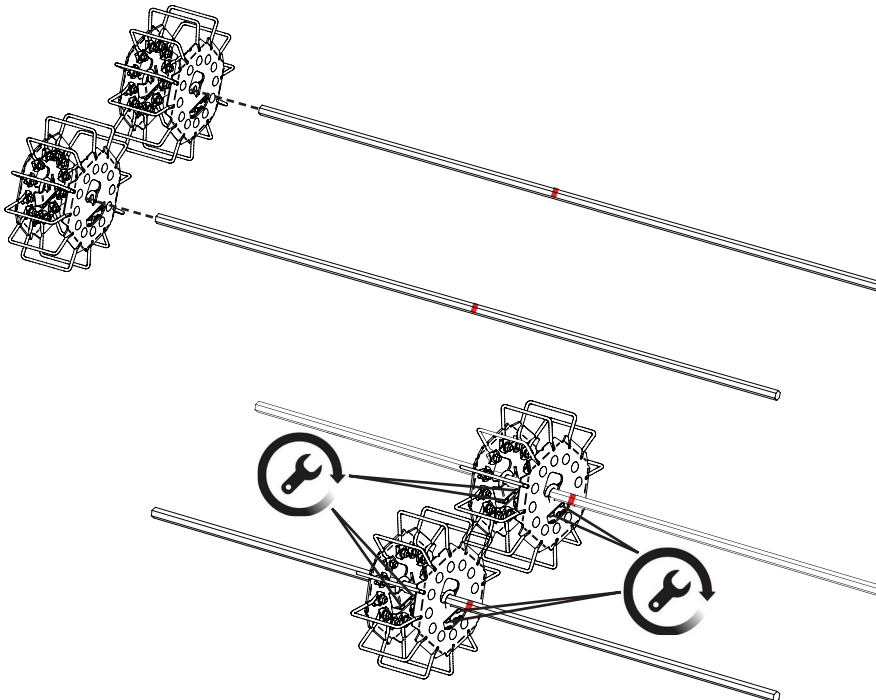

The center mark will either indicate the middle plant row for odd row numbers or the center of the middle basket(s) for even row numbers. Work out from the middle measuring for proper spacing between baskets based on order configuration.

2 CONT'D

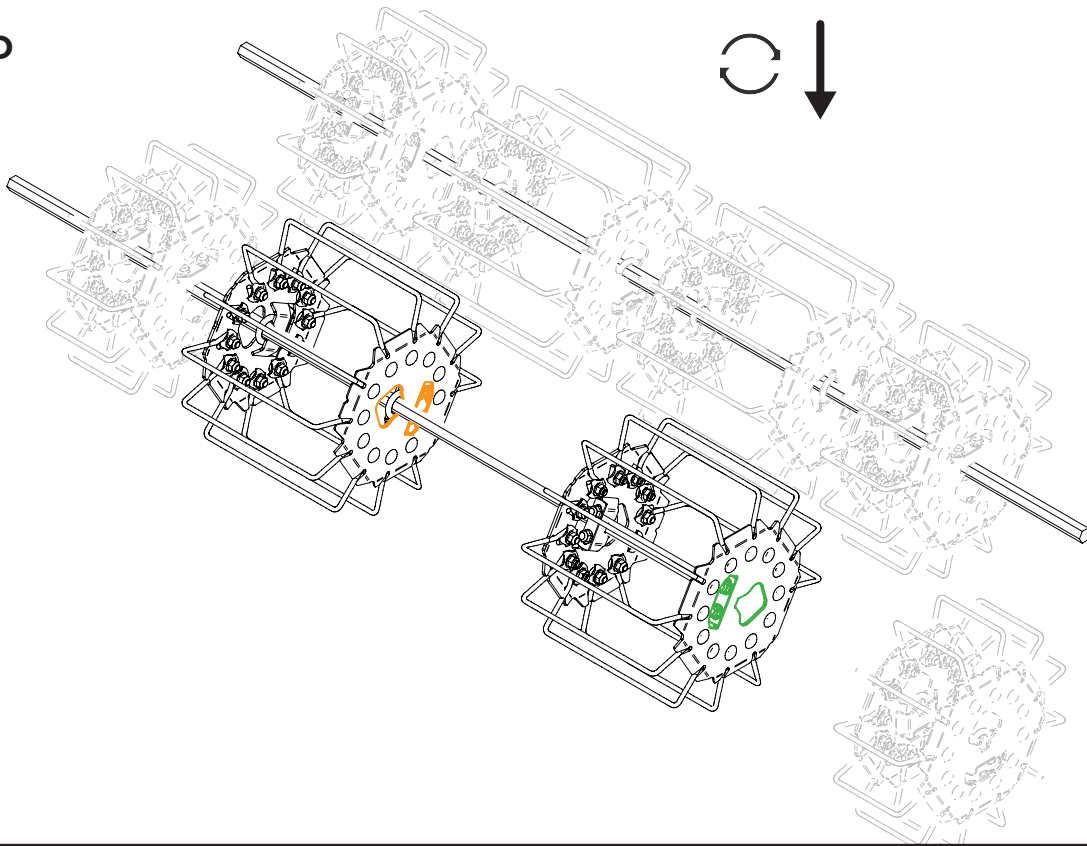

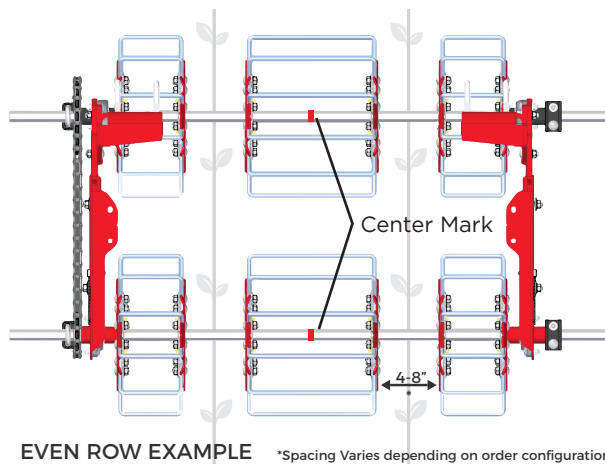
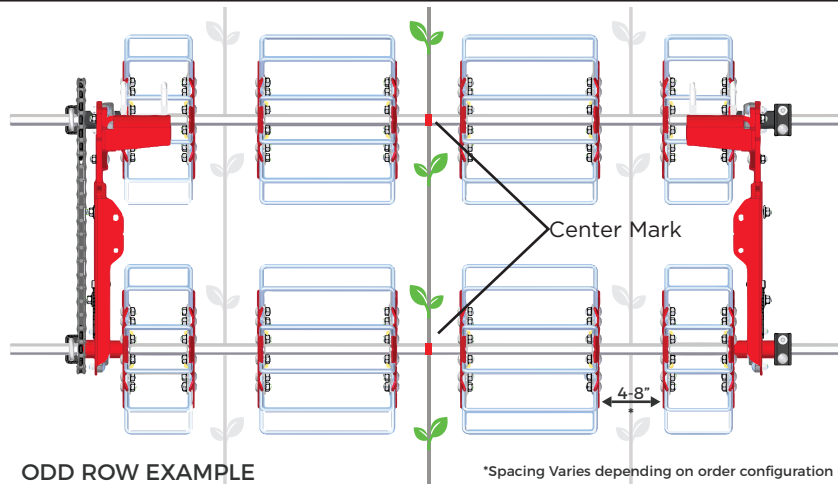

Install baskets so the holes in the side plates on adjoining baskets are not in alignment before tightening to axle. This ensures the baskets are more equally balanced around the axle. See Orange and Green highlights for reference.



FRAME INSTALLATION (RIGHT SIDE)



9/16" WRENCH OR SOCKET

	Black Long	1x
	Black Short	1x
	Red	2x

1

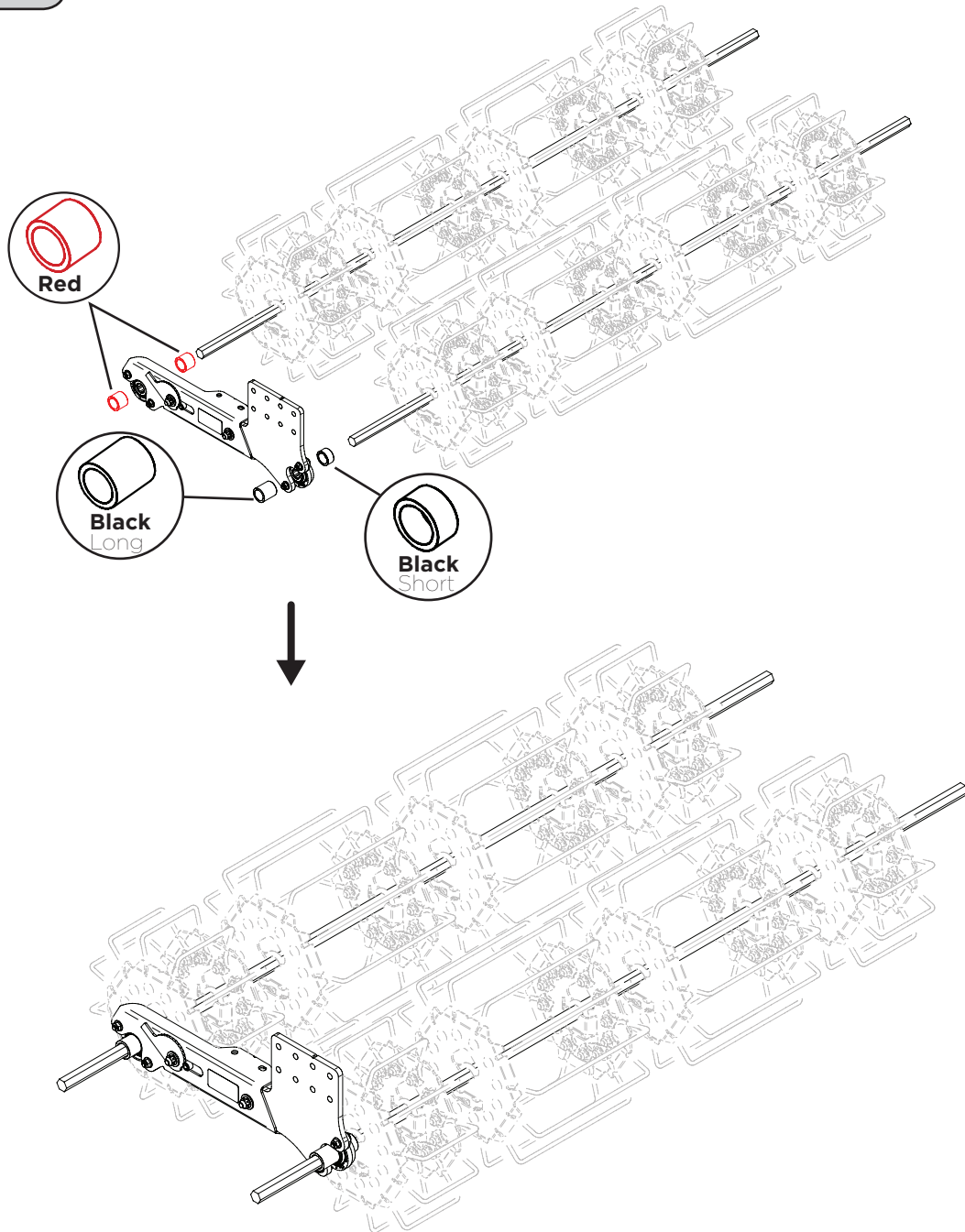

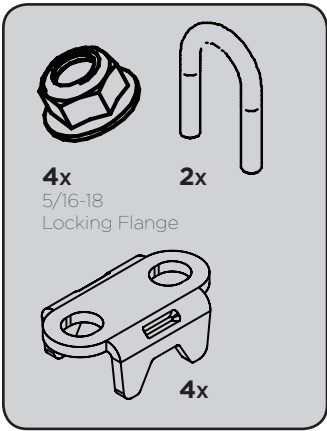

2

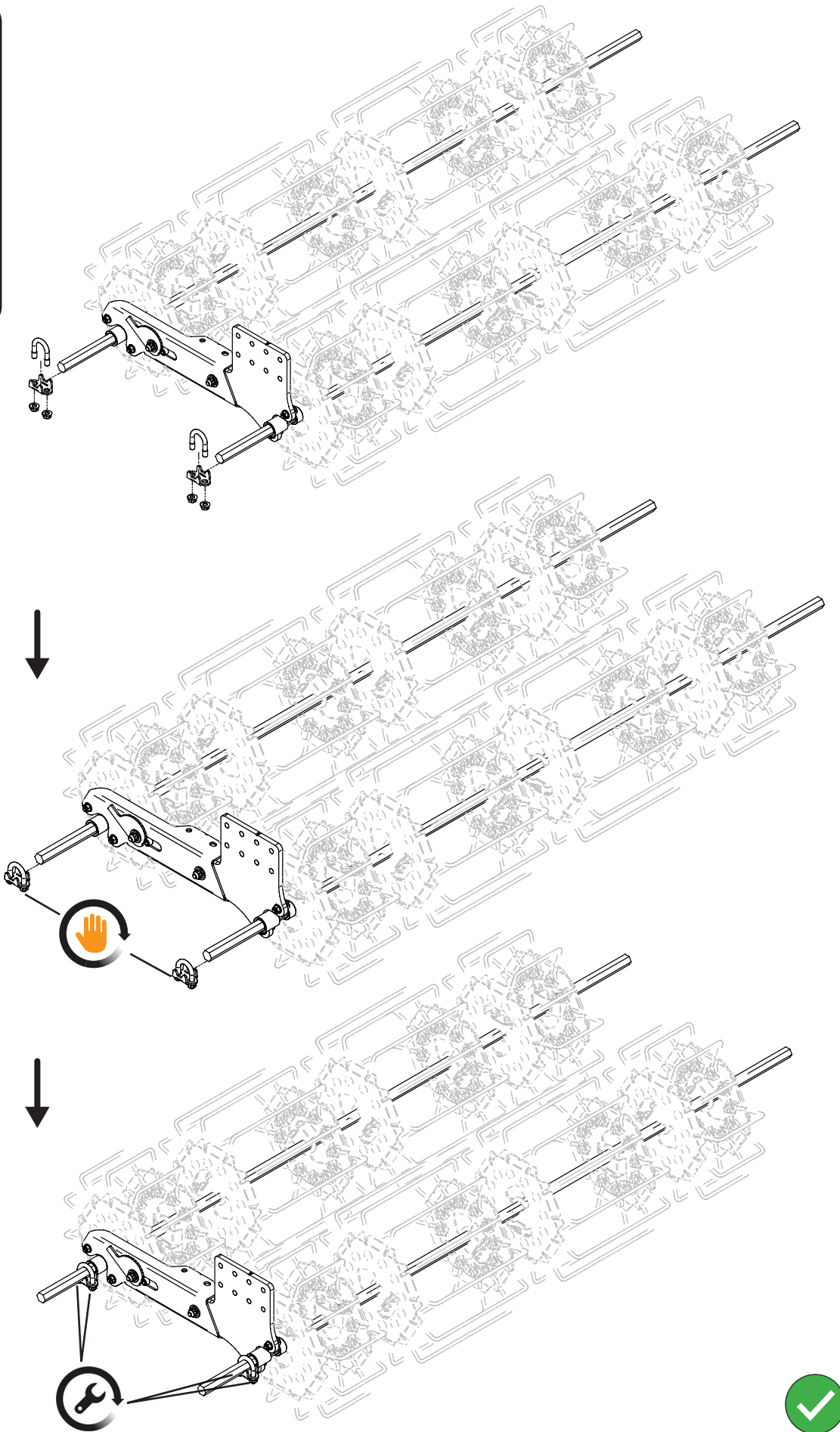

FRAME INSTALLATION (LEFT SIDE)



9/16" WRENCH OR SOCKET AND NEEDLE NOSE PLIERS

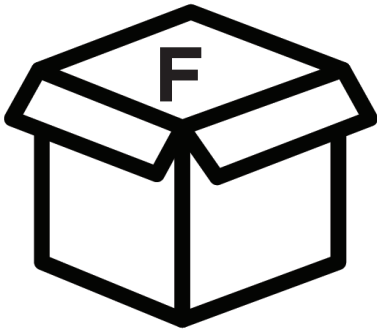

=

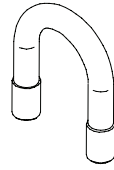

2x
11.0082

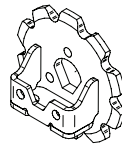

1x
AW-3091

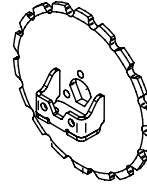

1x
AW-3092

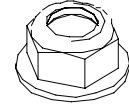

4x
99.E0082
3/8-16 Locking Flange

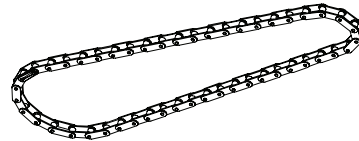

1x
81.0169

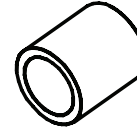

1x
AW-1085
1.375" - Long

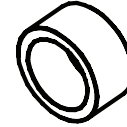

1x
AW-1093
.625" - Short



2x
AW-1086
1"

	Black Long	1x
	Black Short	1x
	Red	2x

1

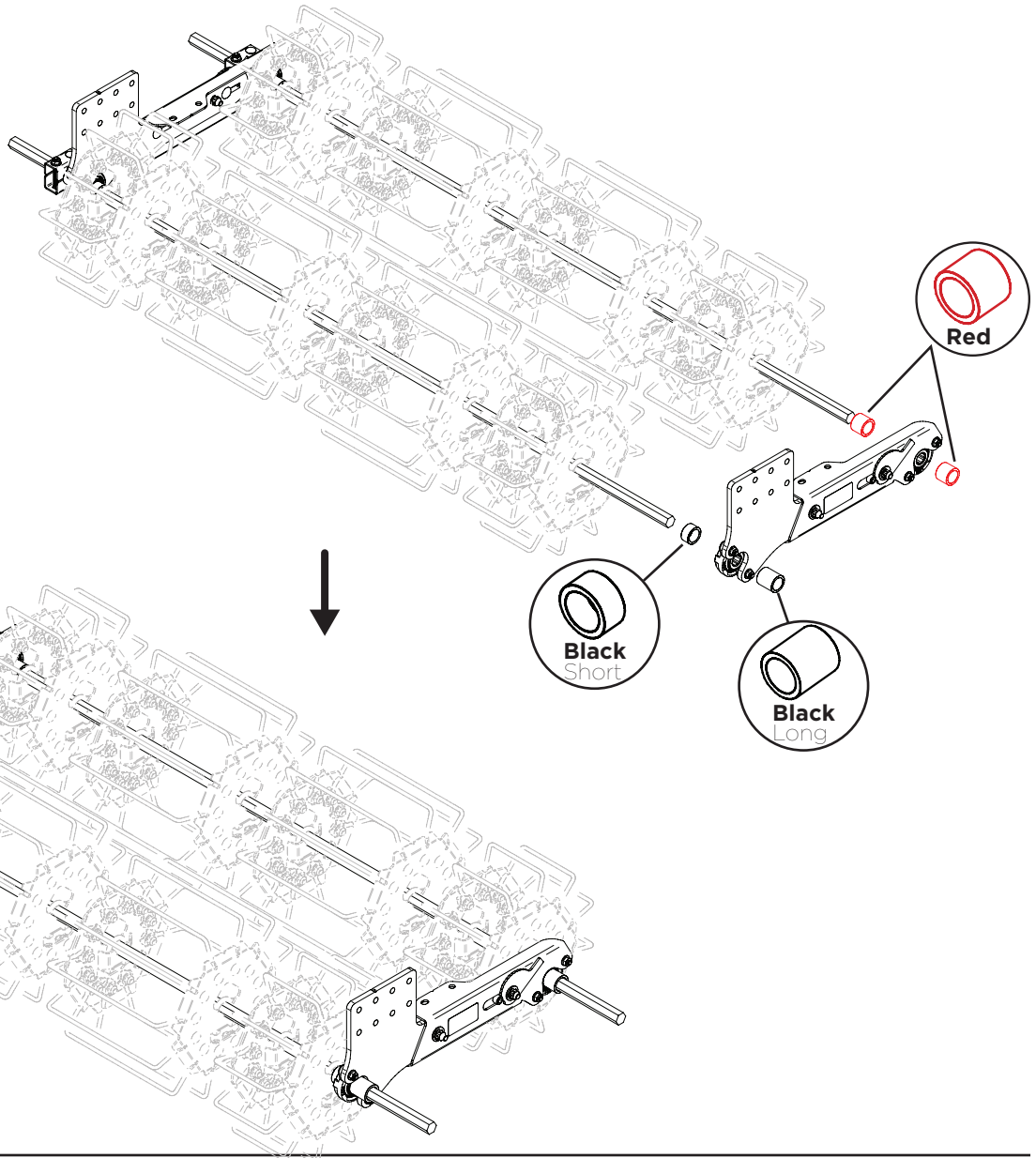

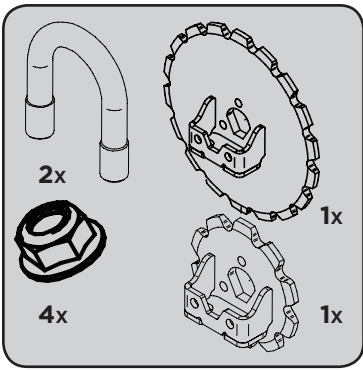

2

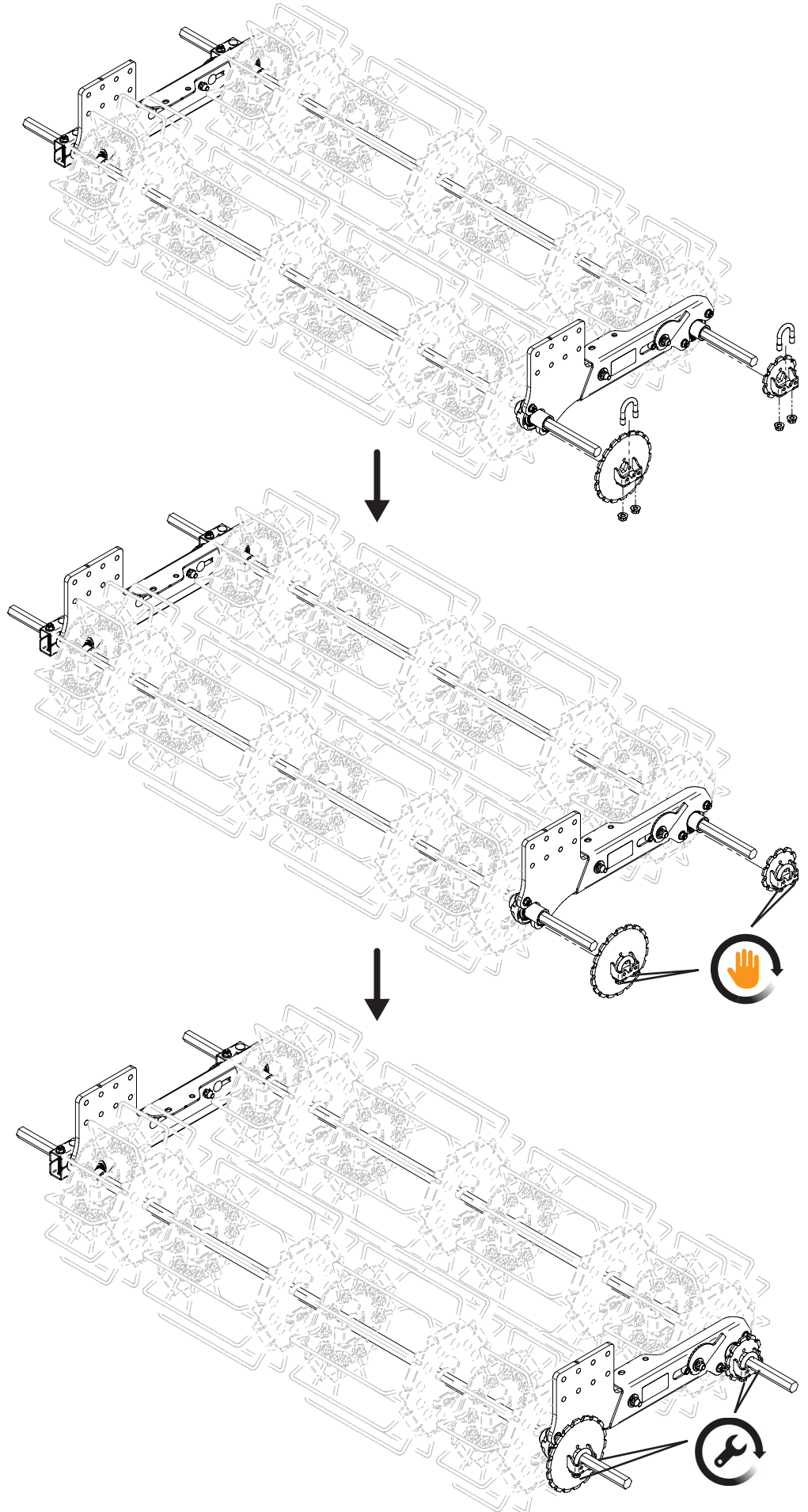

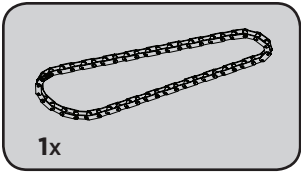

3

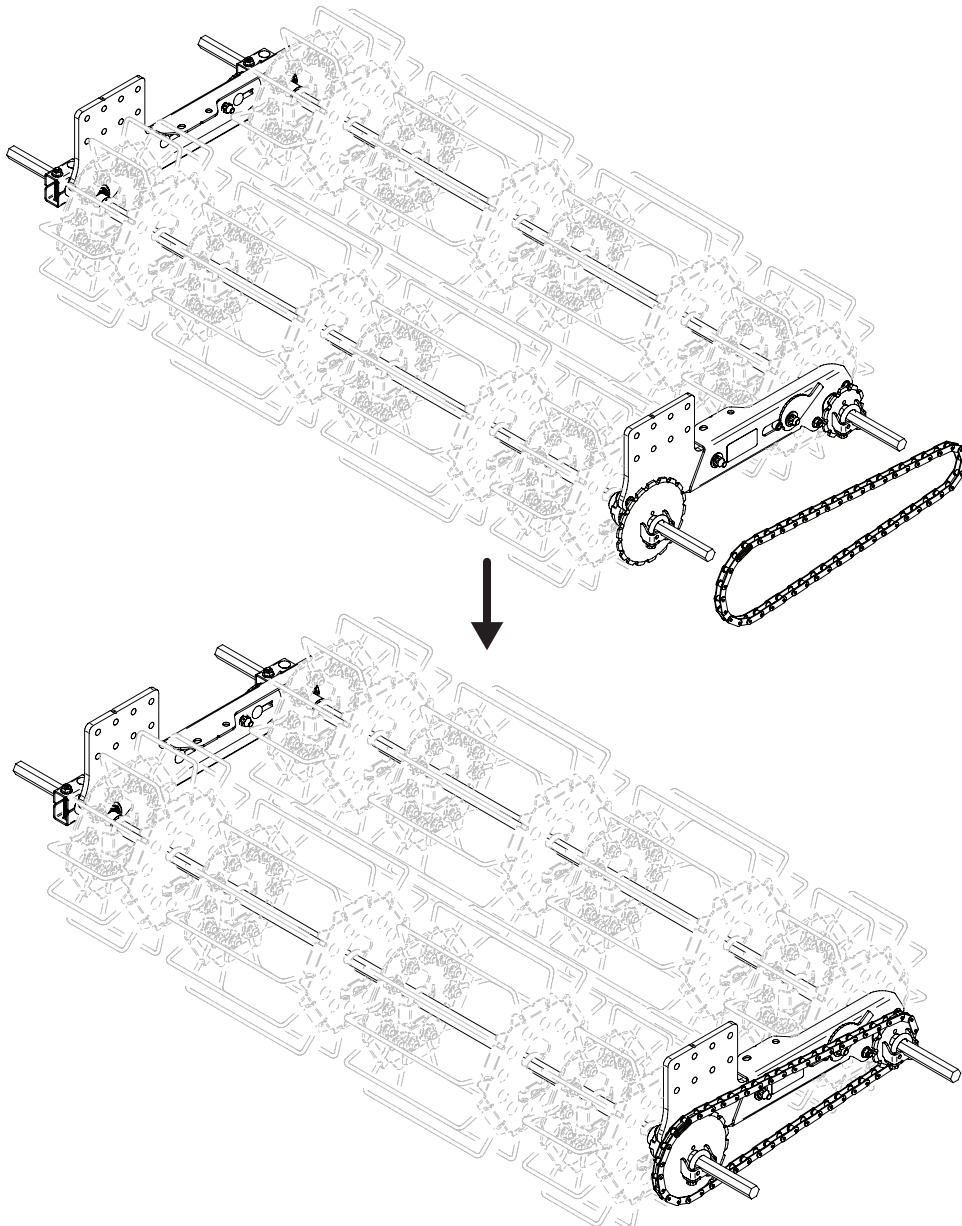
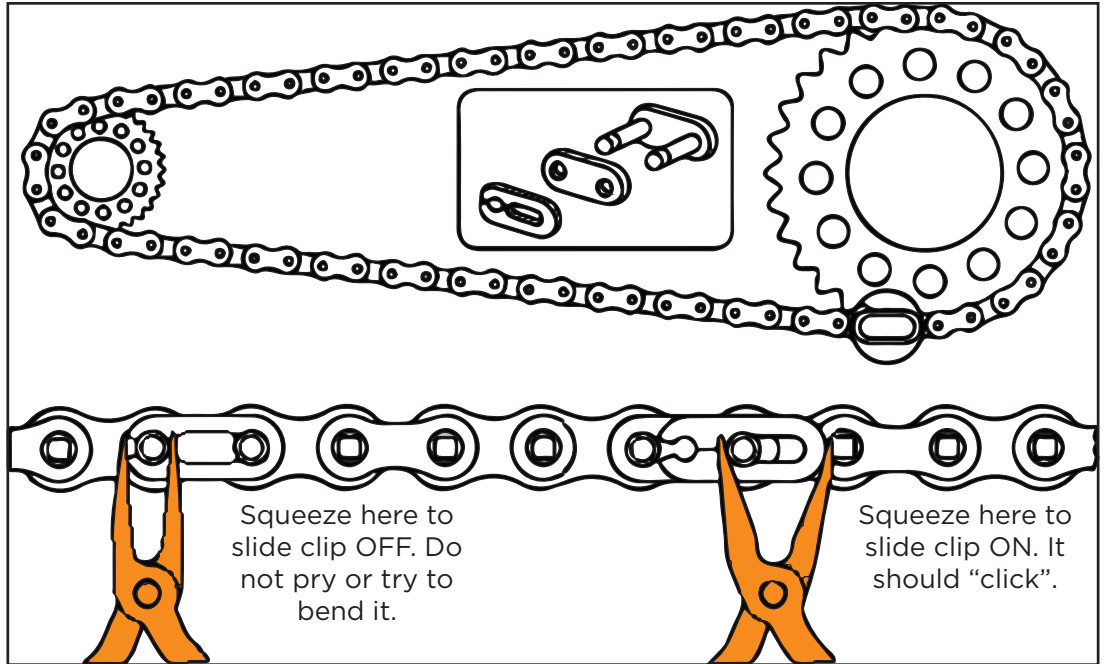

ADJUSTING CHAIN



9/16" WRENCH OR SOCKET

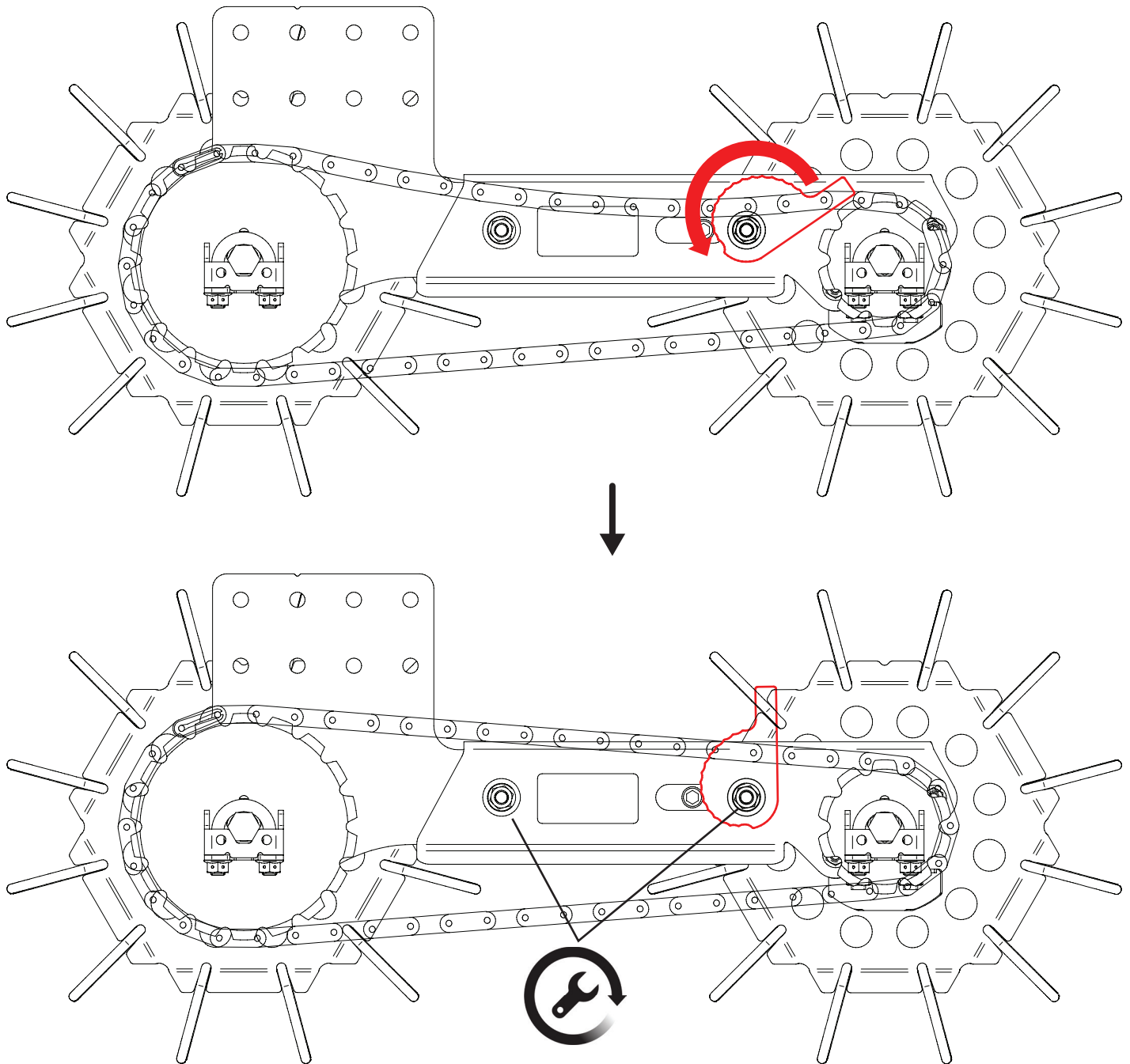

There should be approximately 3/4"-1" of deflection when applying pressure to the chain.



Lubrication: Lightly lubricate chain before use and periodically thereafter based on usage. Wipe off excess oil. Avoid over-lubrication which causes accumulation of dirt. Food-grade lubricants may be used, but clean 20 or 30 weight oil is acceptable.

SQUARING FRAME



9/16" WRENCH OR SOCKET

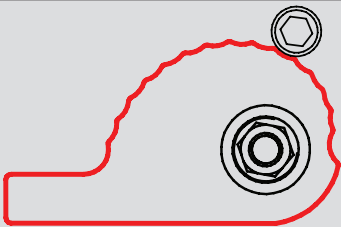
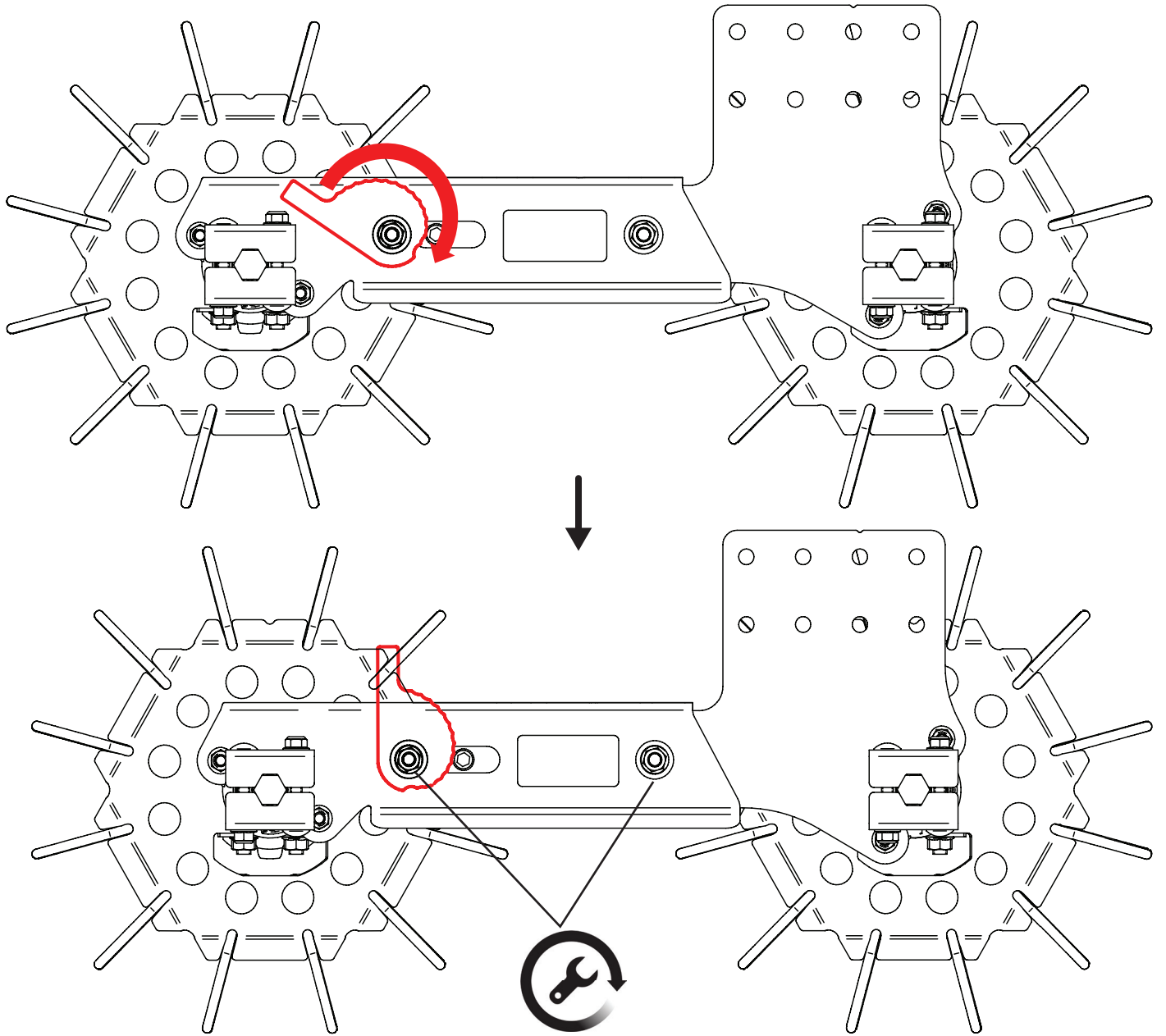

The tensioner (shown in red) should be positioned so that the same notch/indentation is engaged with the cap screw on both sides of the frame. This will ensure that the frame is square. Your tensioner position may be different than the sample image.



MOUNT INSTALLATION



9/16" WRENCH OR SOCKET

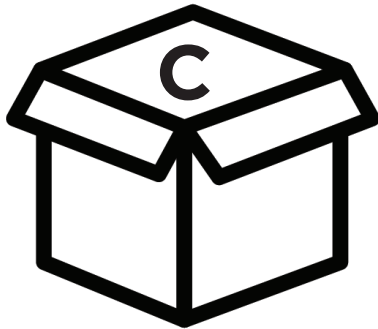

=

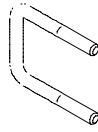

4x
11.0053

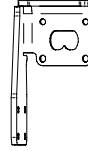

1x
AW-1056
or
AW-1061

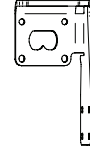

1x
AW-1057
or
AW-1062

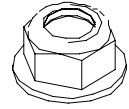

8x
99.E0082
3/8-16 Locking Flange



Qty. 8 of 97.0610 and Qty. 8 of 99.E0082 from frame assembly (Box D) are used in this step.

MOUNT INSTALLATION (LEFT SIDE)

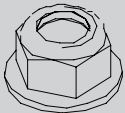

4x
3/8-16
Locking Flange



4x
Carriage Bolt
3/8-16 x 1 1/4



1x

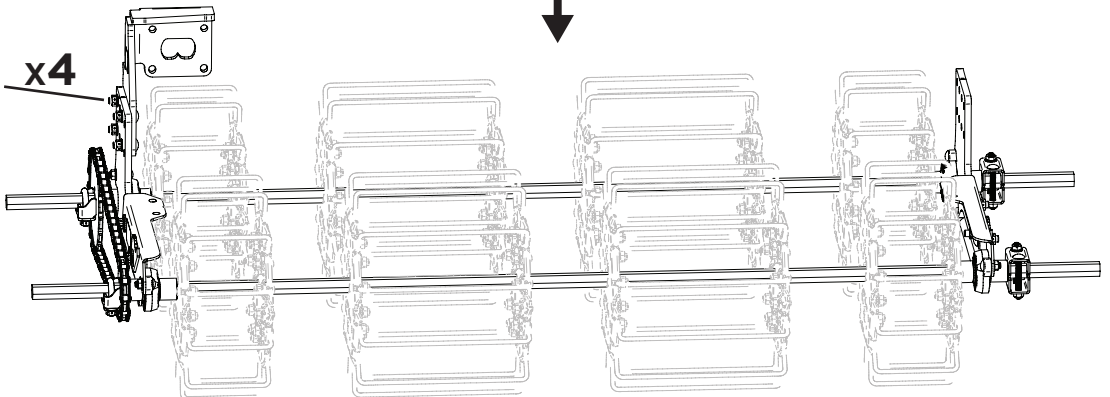
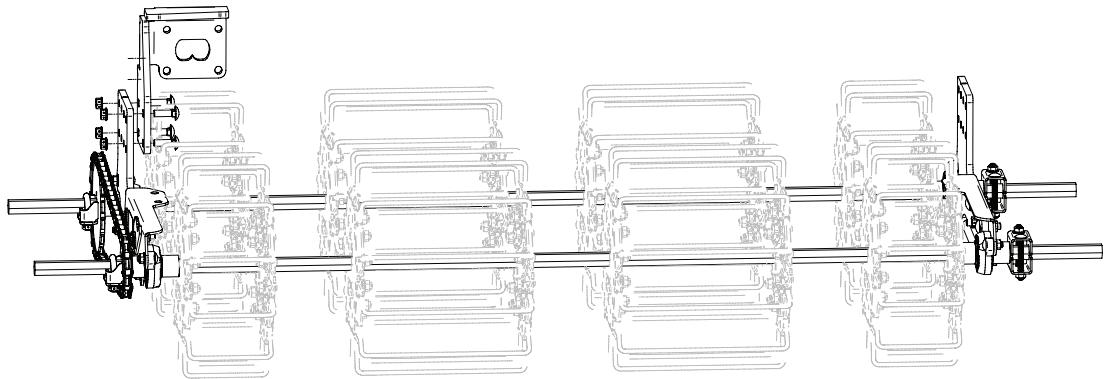

MOUNT INSTALLATION (RIGHT SIDE)

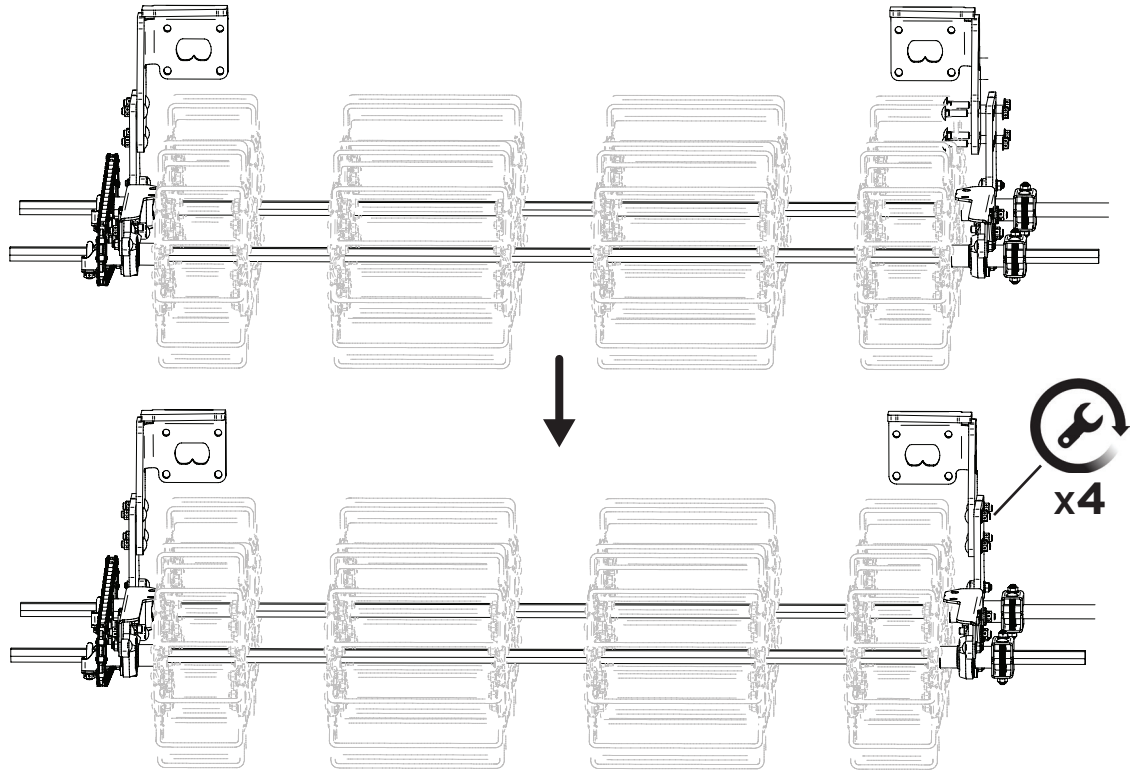
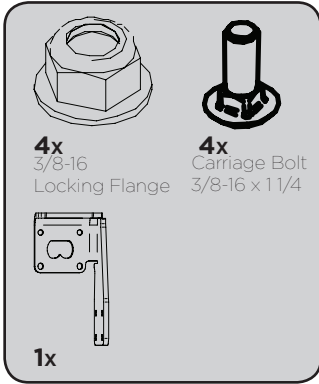

Choosing a mount location: Position the basket weeder under the tractor without the mounting brackets. Check clearance on all sides of the basket weeder. The AW-1056 and AW-1057 mounting brackets may be installed on either side of the basket weeder frame and in two different locations (front or rear). If AW-1056 is installed on the left side and AW-1057 is on the right side, the basket weeder may be positioned backward as far as possible (A). If AW-1056 is installed on the right side and AW-1057 is on the left side, the basket weeder may be positioned forward as far as possible (B). Choose the sets of four bolt holes (F-front or R-rear) that provide the most clearance on all sides of the basket weeder and install the mounting brackets.

The location of AW-1056 and AW-1057 may also depend on other factors like obstacles on the tractor. The flanges face different directions. Positioning AW-1057 on the left and AW-1056 on the right allows for greater separation of the brackets.

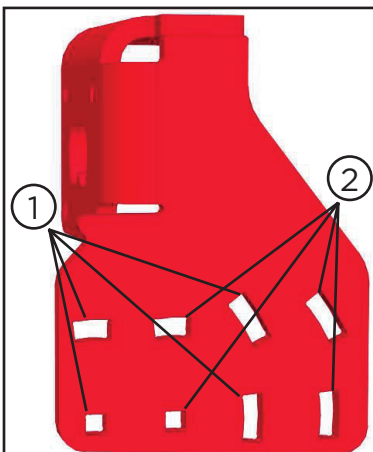
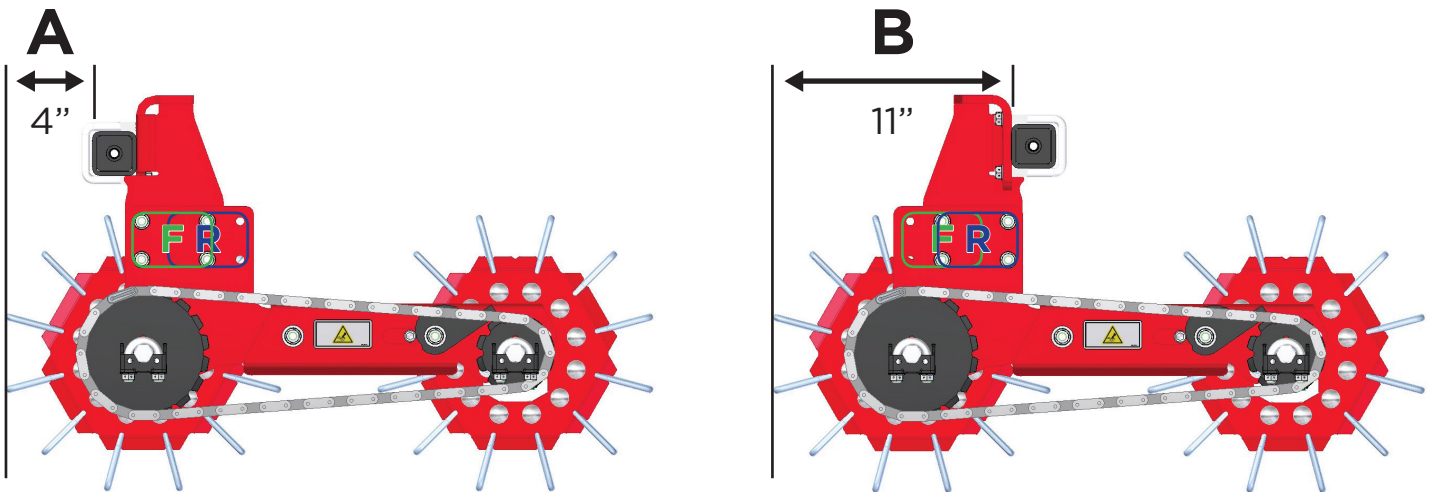

For configurations that include the Universal Mount (pictured left), there are two positions that the Locking Flange Nuts and Carriage Bolts can be installed on the mounting bracket to provide more flexibility when installing on mid-mount tractors.

Angle Adjustment: The slotted cutouts allow for adding a slight forward pitch to the Basket Weeder assembly if a more aggressive drive wheel is desired.

AW-1061 and AW-1062



TOOLBAR INSTALLATION



9/16" WRENCH

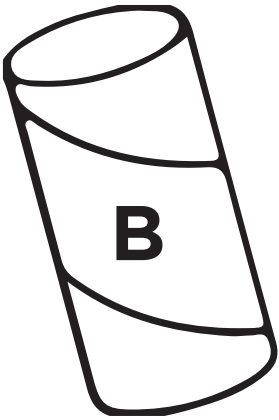

=

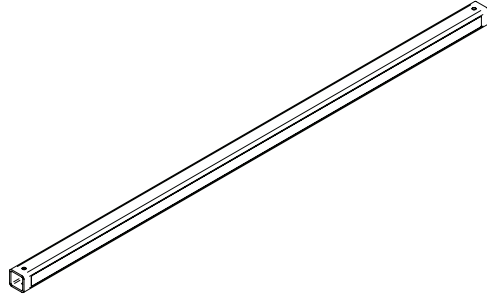

1x
2' Square Toolbar

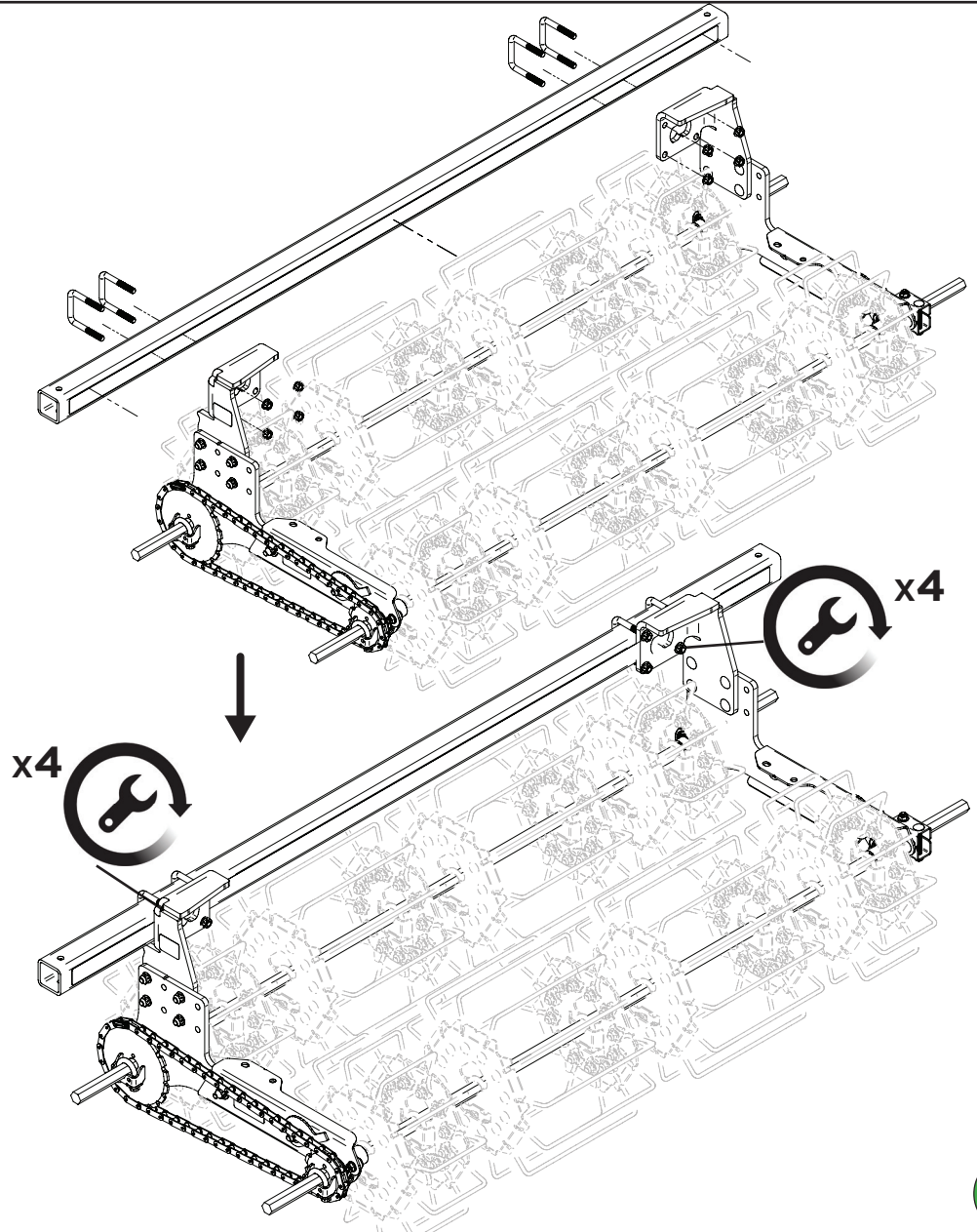
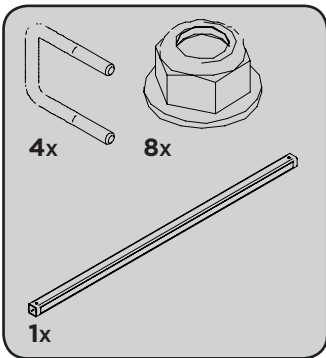

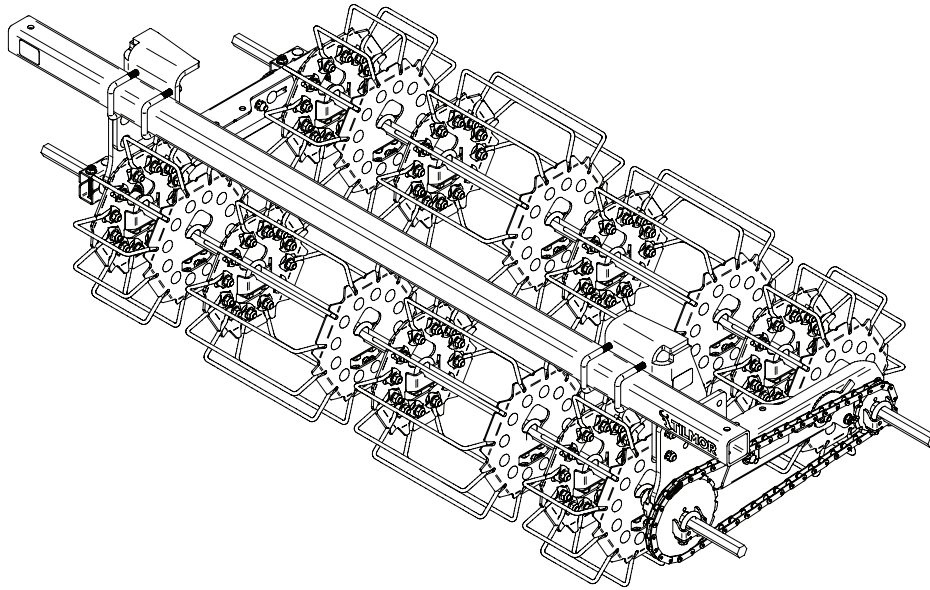

Keep fingers and loose clothing away from sprockets and chains.

ATTENTION: Review safety information before operation.

ATTENTION: Examiner les consignes de sécurité avant l'utilisation.

ADVERTENCIA: Revisar la información de seguridad antes de la operación.

WARRANTY

Unless otherwise stated, all non-serialized Tilmor products are protected against defects in materials and workmanship, under ordinary and normal use, for a period of one year from the shipping date. Under the terms of the warranty, Tilmor may opt to repair, replace, or issue a refund for products that are defective or have sustained damage in shipping. Replacement of products or parts subject to normal wear and tear is the responsibility of the customer. If Tilmor chooses to accept a return under warranty, you may return the defective or damaged product only after you call and receive a Return Merchandise Authorization (RMA) from Tilmor. Warranties on non-serialized Tilmor products are non-transferable.

ON FARM TRIAL

We want you to be completely satisfied with your Tilmor purchase. If for any reason you are not satisfied with your purchase, you may return non-serialized Tilmor branded equipment within 90 days of the original ship date. If returning an item, you will first need to contact a Tilmor customer support representative at 1-844-255-5864 to obtain a return merchandise authorization (RMA) prior to shipping the item to Tilmor. Shipping costs for returns will be incurred by the customer. After receiving the returned item, an exchange or full refund of the product's original price will be given, less shipping charges to and from the delivery address. All new and unused products may be returned within 30 days of the ship date for a full refund. For more information, please call 1-844-255-5864.

LEGAL NOTICES

Venture Products Inc. reserves the right to make changes in design or specifications without incurring obligation to make like changes on previously manufactured products.



Copyright © 2017 Venture Products, Inc.
All rights reserved.

1-844-255-5864

Tilmor, 500 Venture Drive. Orrville, OH 44667

www.tilmor.com