

Go to www.tilmor.com/resources for complete parts list, additional resources and replacement part ordering.

Release Date: 09/25/2018
 Document Number: 12.50002
 Revision Number: 00

ATTENTION
 Review safety information before operation.

 Tools

- 9/16" wrench
- 5/8" wrench
- 3/4" wrench
- 9/16" socket
- 5/8" socket
- 3/4" socket
- Torque Wrench
- Extension

Assembly Time (estimated)

1 hour

REQUIRED PARTS

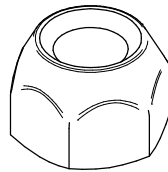
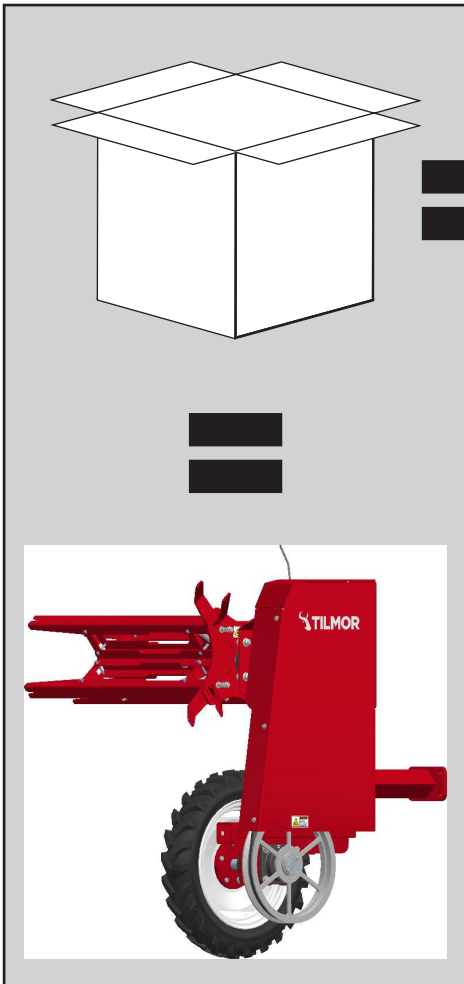

5x
99.E0044
7/16" Lug Nut

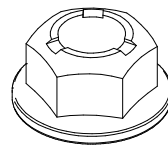

8x
99.E0103
1/2" Locking
Flange Nut

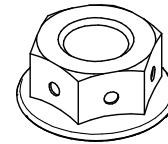

1x
99.E0082
3/8" Locking
Flange Nut

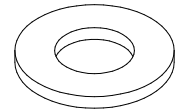

4x
95.08
1/2" Flat Washer

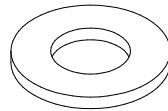

1x
95.06
3/8" Flat washer

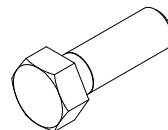

1x
90.0620
3/8" x 2-1/4" Hex
Bolt

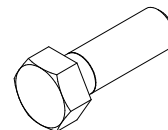

4x
90.0812
1/2" x 1-1/2" Hex
Bolt

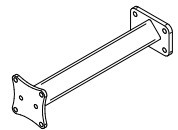

1x
AB-6005
Tool Bar Mount-
ing Bracket

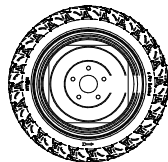

1x
53.0182-R
Wheel and Tire

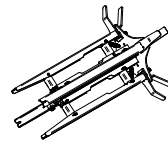

1x
Reel Assembly



There is additional hardware in the box. The additional hardware is used for the installation of the plastic winder onto a tool bar. The installation instructions are found in the Plastic Winder Operations Manual.

PLASTIC WINDER ASSEMBLY

 3/4" wrench, 3/4" socket, Torque wrench

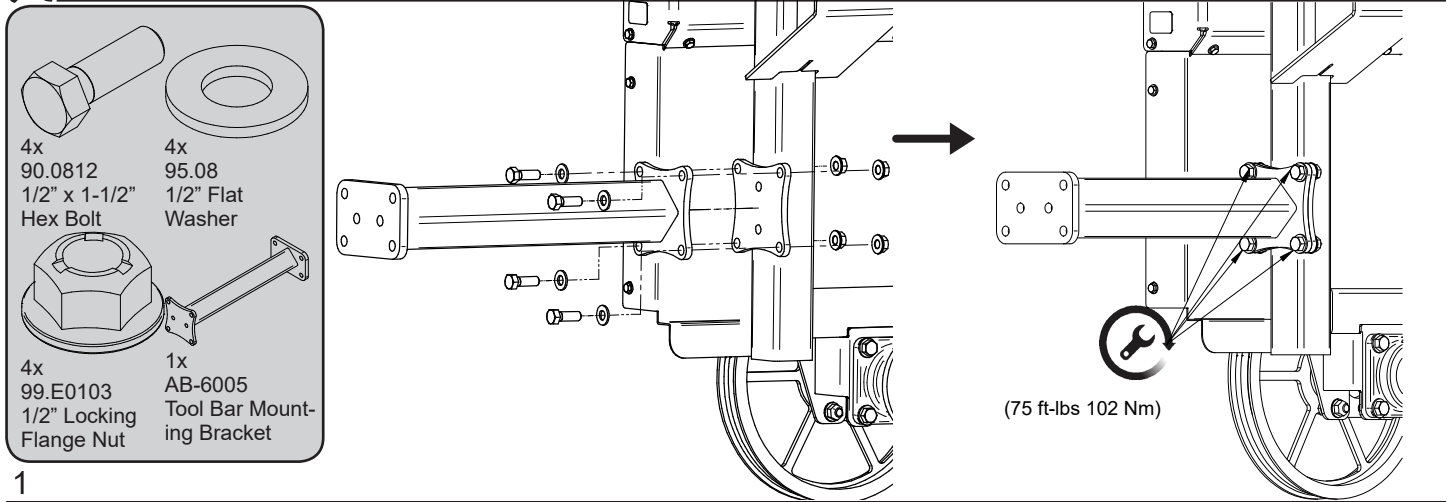

 5/8" socket, Torque wrench, Extension

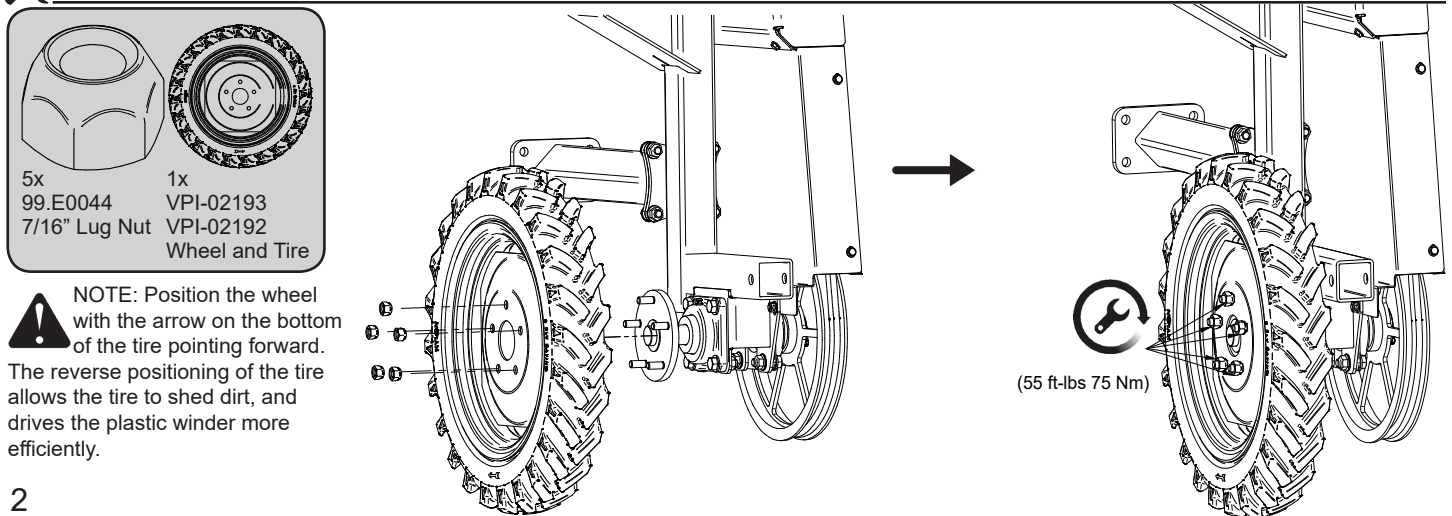

 9/16" socket, 9/16" wrench, Torque wrench, Extension

