

## Drive Axle Flange Bearing Replacement

Document Number	Model	Serial Number Range	Part Number
12-80002	AB-100 Plastic Winder	All Units	55-FB22020

### ⚠ WARNING

Before making repairs or adjustments set the parking brake, turn off the engine, and remove the ignition key.

Always disconnect the negative battery cable from the battery when working with electrical components. Always work in a manner that does not put safety at risk!

### ⚠ WARNING

Safety glasses must be worn during installation. Ear (hearing) protection must be worn when using air or power tools.

**Installation Notes:** Right and left hand orientation referred to in these instructions is determined as if facing forward from the operator station.

**Installation Time (estimated)** 1 hour 30 minutes

**Tools Required:** 7/16" wrench, 5/8" socket, 3/4" wrench, 3/4" socket, 3/16" hex key, Torque wrench, Ratchet, Hammer, Dead blow hammer

- Lift the plastic winder with the 3 point hitch or a hoist so that the drive wheel is off of the ground.
- Remove the five lug nuts and remove the wheel and tire from the hub.
- Remove the tension from the belt by adjusting the tensioner (A) to the lowest position (B).
- Remove the seven 1/4" bolts (D) and the seven 1/4" flat washers (E) around the outside perimeter of the pulley cover.
- Remove the pulley cover (C).
- Remove the belt from the pulleys. Retain the belt for later use.
- Remove the two 1/4" bolts and washers (F).

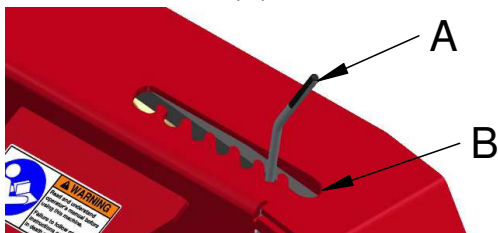

- Remove the seven 1/4" bolts (D) and the seven 1/4" flat washers (E) around the outside perimeter of the pulley cover.

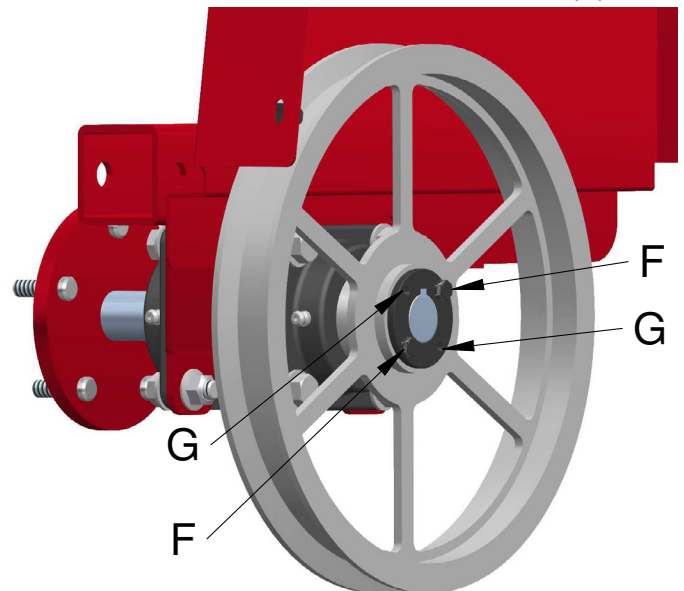
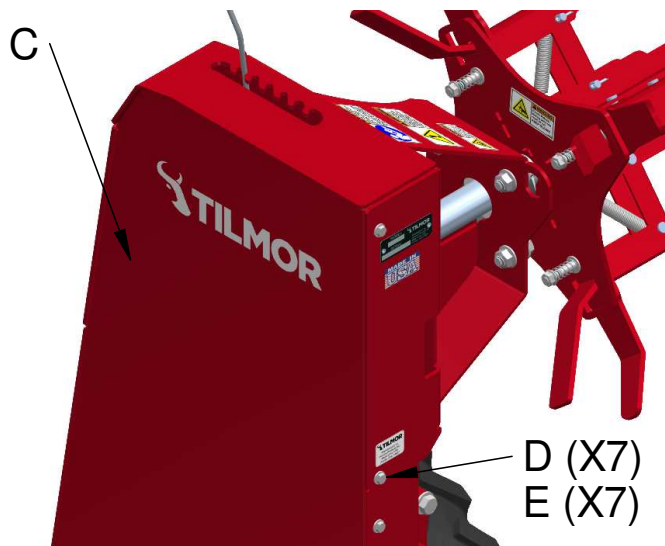

- Thread the removed bolts into the threaded holes (G) hand tight. Tighten the bolts, alternating between the bolts 1/4 turn each time to remove the bushing evenly.
- Retain the bushing, key, and hardware for later use.
- Remove the pulley from the axle.

11. Loosen the set screw (H) using a 3/16" hex key.

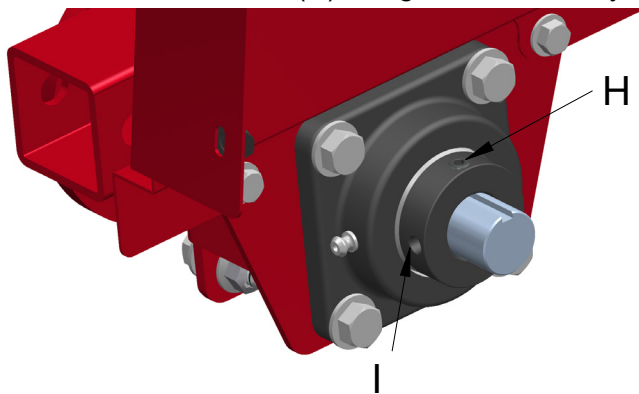

12. Using a punch and hammer loosen the collars by placing the punch in the indent (I) and hitting the collar.

	<b>Attention</b>
NOTE: The collars must be removed from both of the axle flange bearings before the axle can be removed.	

 <b>CAUTION</b>	
Use caution when removing the axle using a hammer not to bend or damage the axle, hub, or flange bearing.	

13. Remove the axle from the flange bearings using a dead blow hammer.

	<b>Attention</b>
NOTE: the location of the grease fitting before removing the flange bearing. Ensure that the new bearing is installed in the same orientation.	

14. Remove the 1/2" bolts (J), and lock nuts (K) from the flange bearing that will be replaced. Retain the hardware for later use.

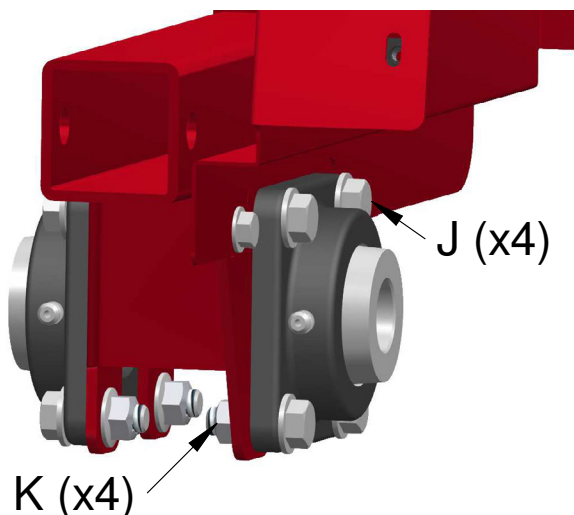

	<b>Attention</b>
NOTE: If only one of the flange bearings is being replaced, it is necessary to loosen the mounting hardware of the other flange bearing before installation of the axle.	

15. Remove and discard the flange bearing.
16. Position the new flange bearing with the grease fitting in the same orientation as the removed bearing.
17. Install four 1/2" bolts with washers through the flange bearing and secure in place hand tight with four 1/2" flange nuts.
18. Apply anti-seize to the inside of the bearings before installing the axle.
19. Install the axle through the bearings.
20. Torque the flange bearing mounting hardware to 45 ft-lbs (61 Nm) on both the inner and outer bearings.
21. Place the bearing collars over the ends of the axle and in position against the flange bearings.
22. Measure 1-1/2" from the edge of the collar to the end of the shaft on the outer flange bearing as shown below.

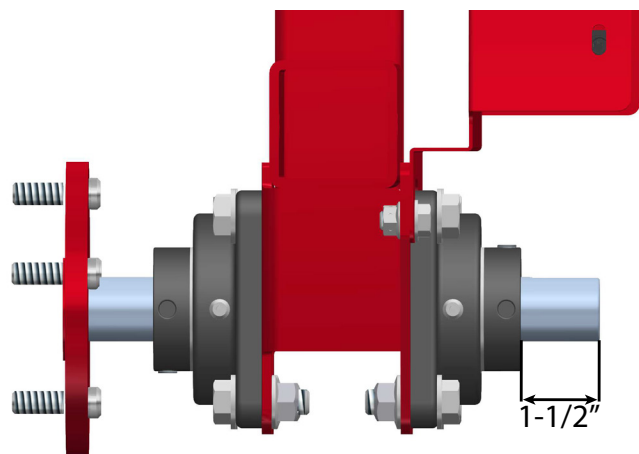

23. Remove the set screws (H) from the locking collars.
24. Lock the collars in place using a punch and hammer by placing the punch in the indent (I) and hitting the collar.
25. Apply blue thread locker to the set screw threads.
26. Install the set screws tightly in the collars using a 3/16" hex key.
27. Apply blue thread locker to the two 1/4" bolts (F).
28. Position the bushing in the pulley aligning the mounting holes.
29. Install the two 1/4" bolts through the bushing and into the pulley hand tight.
30. Install the pulley onto the axle shaft with the key installed in the bushing.

31. Align the pulley with the other pulleys and tighten the bushing bolts, alternating between the bolts making 1/4 turn each time to tighten the bushing evenly.
32. To install the belt, route the belt around the pulleys as shown below.



### Attention

NOTE: The V portion of the belt must be on the plastic winder reel drive pulley (L).

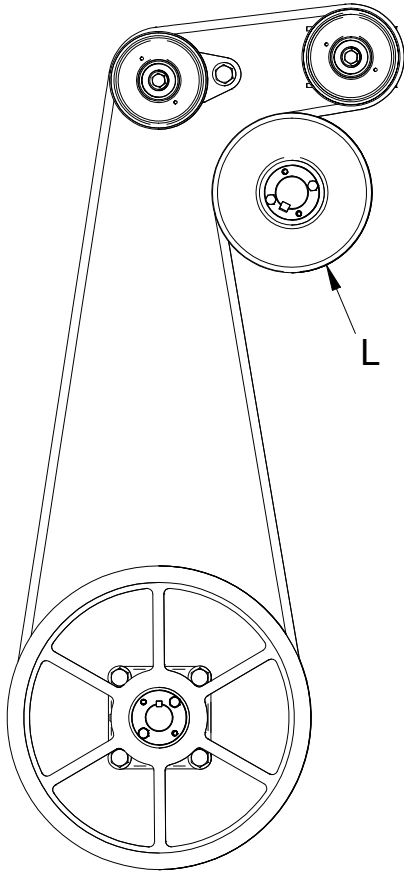

33. Set the belt tension as required by adjusting the tension adjustment lever.
34. Reinstall the pulley cover.
35. Install the wheel and tire on the hub. Securely tighten the lug nuts to 75 ft-lbs (101 Nm).