



Edge of Plastic Weeder Assembly AW-9048

Go to www.tilmor.com/resources for complete parts list, additional resources and replacement part ordering.

Release Date: 02/12/2019
Document Number: 12-70008
Revision Number: 00

ATTENTION
Review safety information before operation.

Tools	
	1/2" Wrench
	1/2" Socket
	9/16" Wrench
	9/16" Socket
	Torque Wrench

Assembly Time (estimated)

15 minutes

REQUIRED PARTS

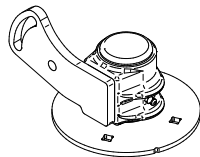
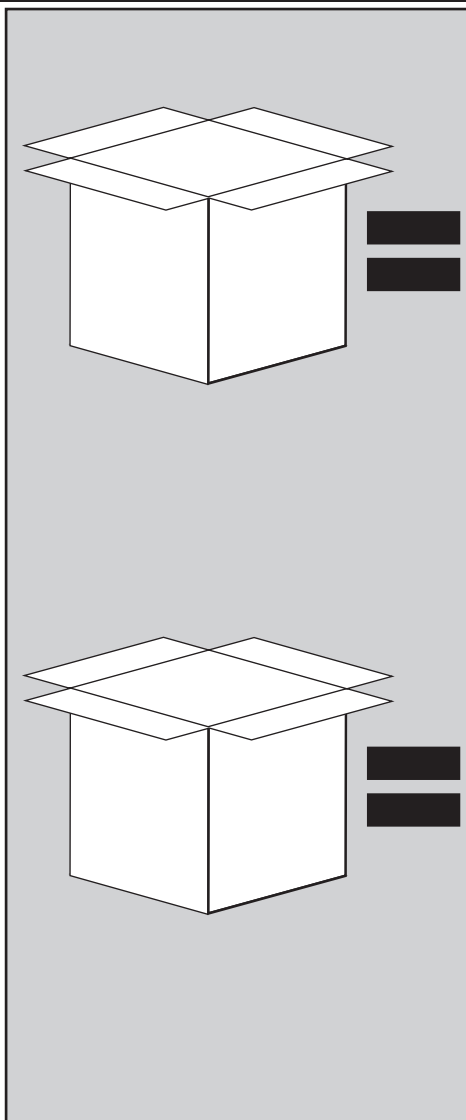

1x
Hub Assembly

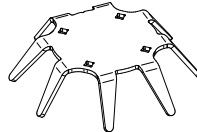

1x
AW-1033
Drive Plate

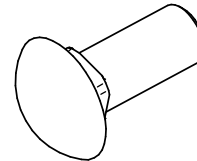

4x
97-0524
Carriage bolt
5/16 x 3"

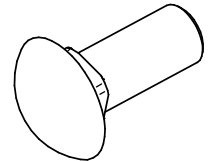

2x
97-0610
Carriage bolt
3/8 x 1-1/4"

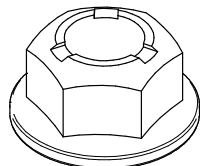

4x
99-E0102
Flange Nut
5/16"

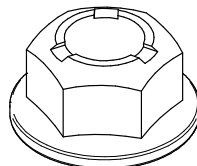

2x
99-SF06
Flange Nut
3/8"

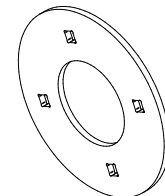

4x
AW-1042
Spacer Plate

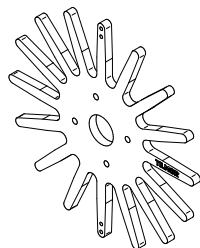

3x
AW-3011 or
AW-3012
Finger Weeder



After the Assembly Procedure Is completed The Edge of Plastic assembly must be greased before use.

ASSEMBLY

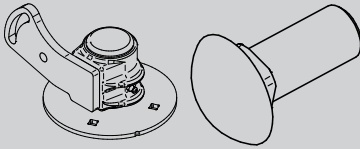

1x
Hub Assembly

4x
Carriage bolt
5/16 x 3"
97-0524

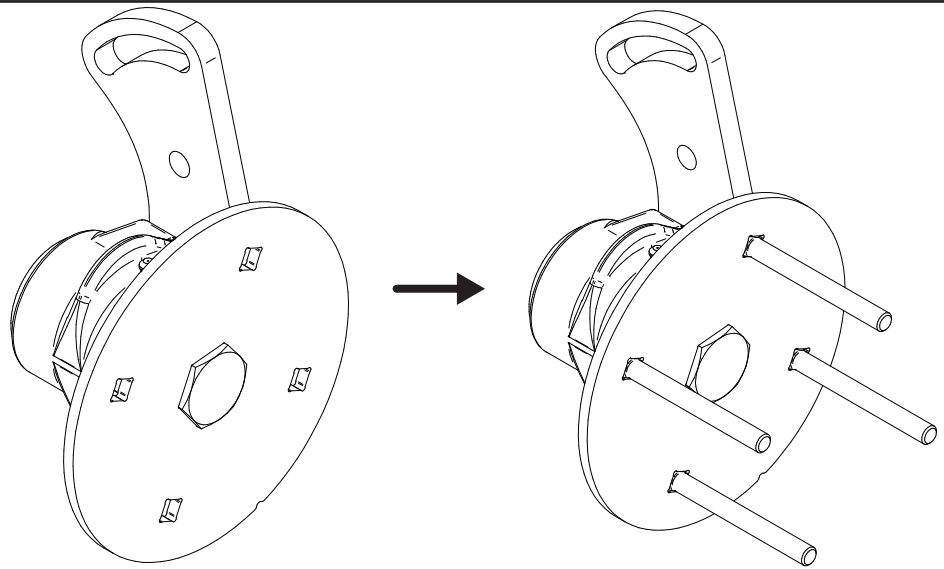

1

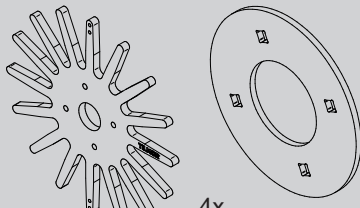

3x
Finger Weeder
AW-3011 or
AW-3012

4x
Spacer Plate
AW-1042

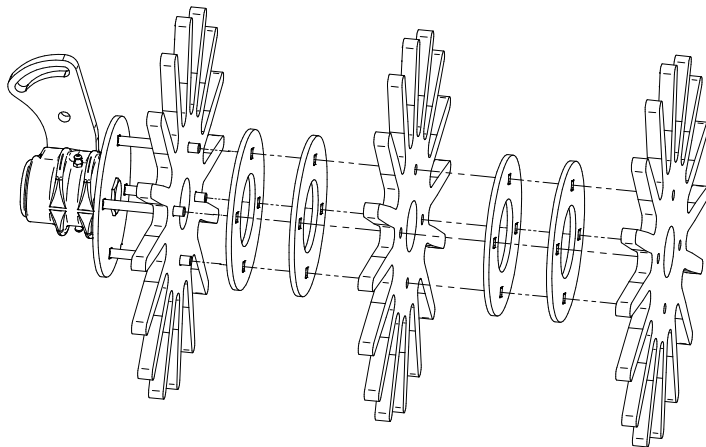

The spacer plates may be placed in any location necessary to provide the best results.

2



1/2" Wrench, 1/2" Socket, Torque Wrench

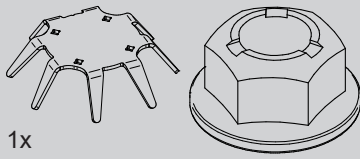

1x
Drive Plate
AW-1033

4x
Flange Nut
5/16"
99-E0102

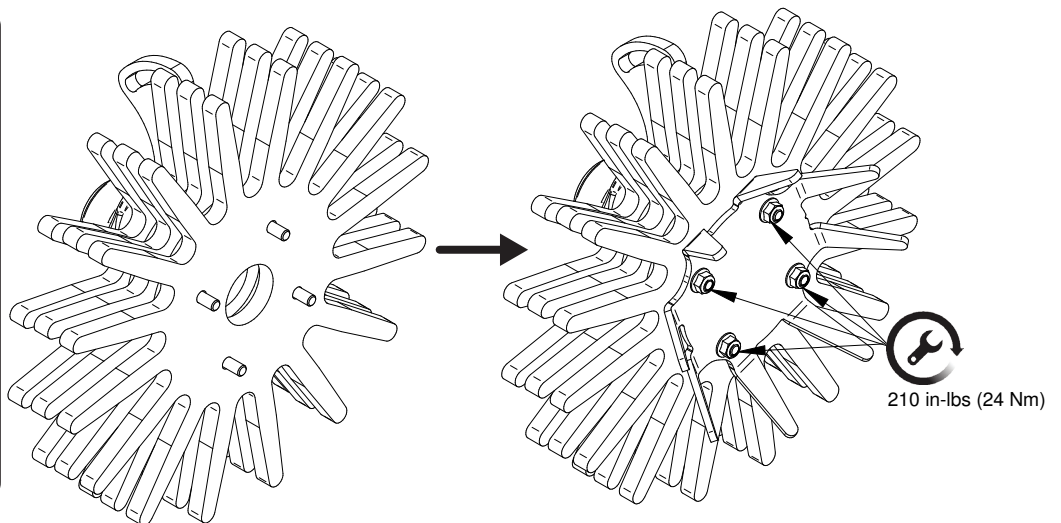

3

RIGHT SIDE INSTALLATION

 9/16" Wrench, 9/16" Socket, Torque Wrench

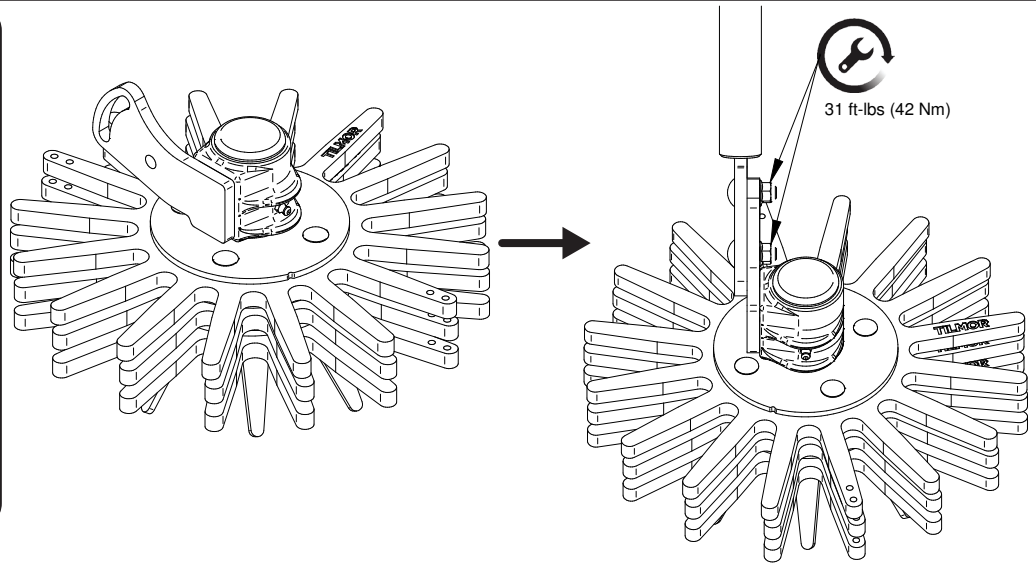
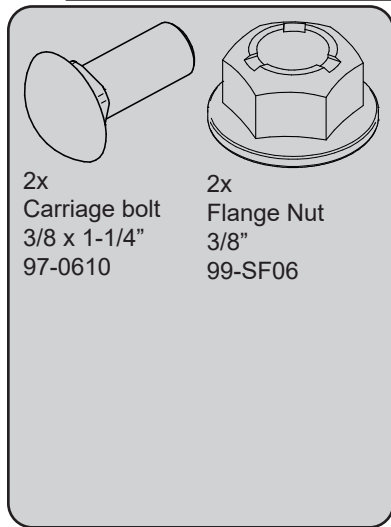

4

 Grease

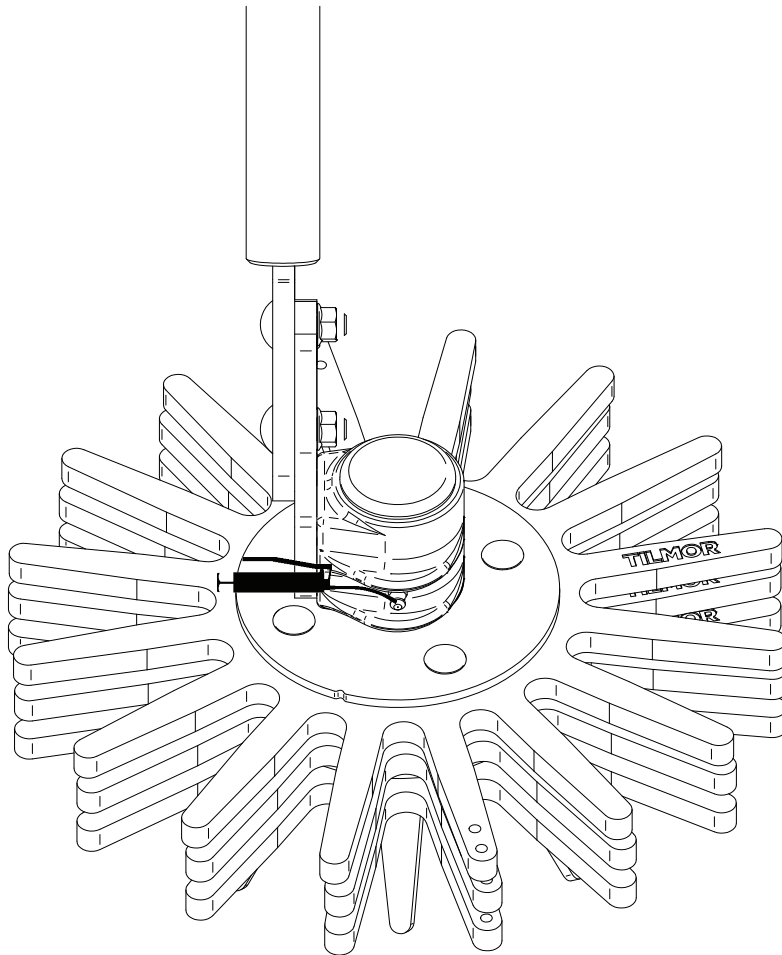

5