

Go to www.tilmor.com/resources for complete parts list, additional resources and replacement part ordering.

Release Date: 03/08/2020
 Document Number: 12-70010
 Revision Number: 01

ATTENTION
 Review safety information before operation.

 Tools
3/4" Wrench 3/4" Socket Ratchet Torque Wrench

Installation Time (estimated) *10 minutes*

REQUIRED PARTS

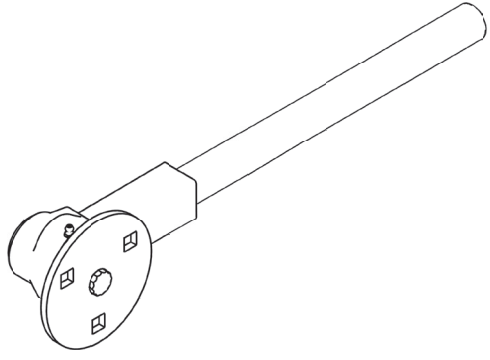
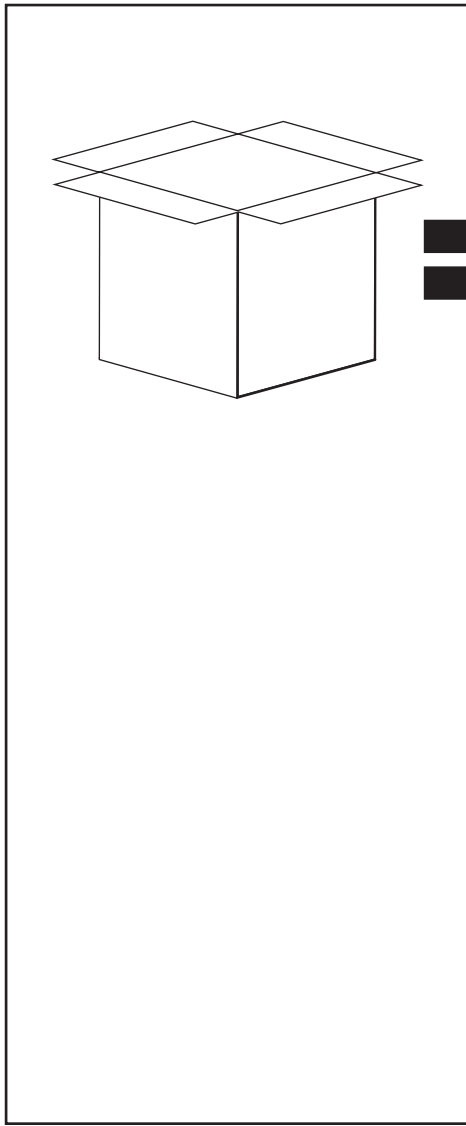

1x
 Spyder Disc
 Mount

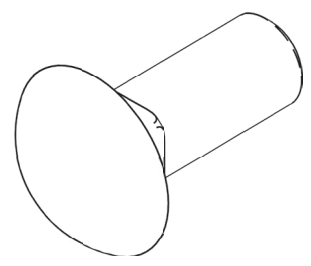

3x
 97-0810
 1/2" x 1-1/4"
 Carriage Bolt

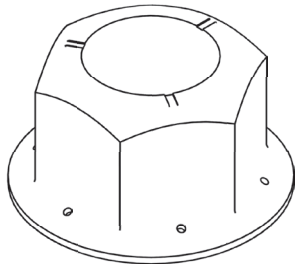

3x
 99-E0103
 1/2" X 1-1/4"
 Flange Nut



After the Assembly Procedure Is completed The Spyder Disc Mount assembly must be greased before use.

ASSEMBLY

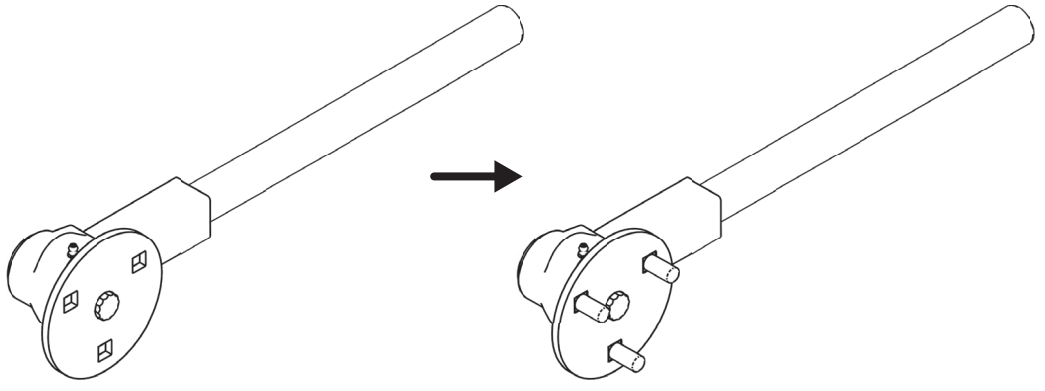
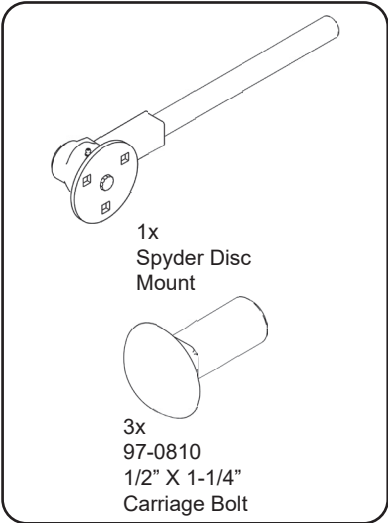

The carriage bolts must be installed as shown. Failure to install the carriage bolts as shown may result in damage to the mount.

1



3/4" Wrench, 3/4" Socket, Torque Wrench

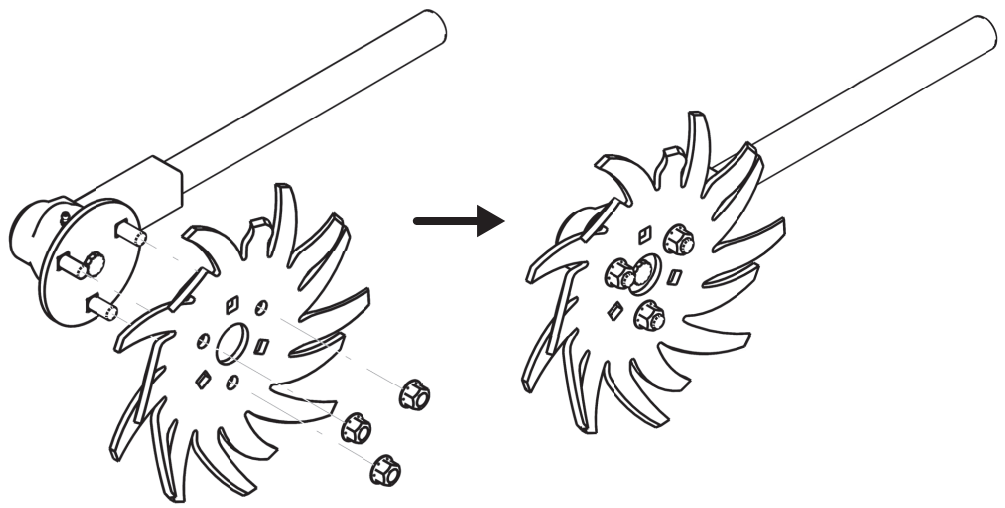
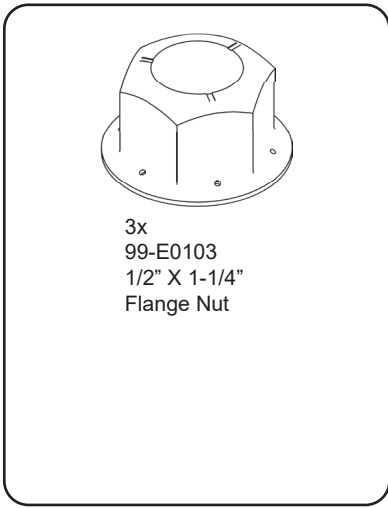

2



Grease

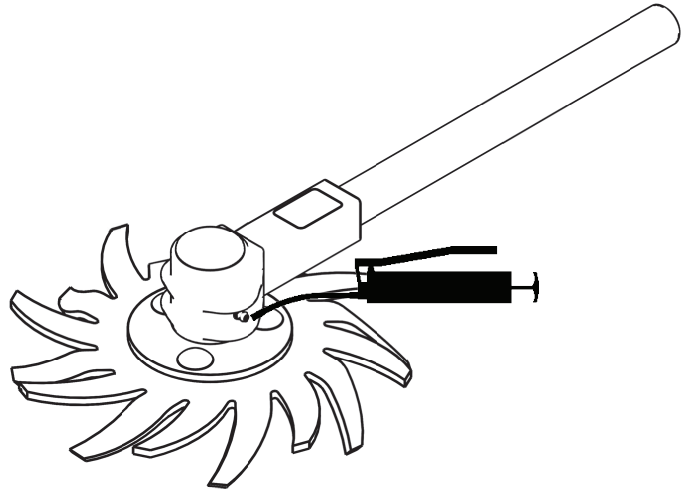

3