





Finger Weeder and A-Blade Kit

(844) 255-5864 info@tilmor.com www.tilmor.com
MADE IN THE USA

 REQUIRED PARTS	 ASSEMBLY TIME	 TOOLS						
KIT-1111 (1 row) OR KIT-1112 (2 row) OR KIT-1137 (3 row)	2hrs (estimated)	<table border="0"> <tr> <td>9/16" Wrench</td> <td>9/16" Socket</td> </tr> <tr> <td>3/4" Wrench</td> <td>3/4" Socket</td> </tr> <tr> <td>5/16" Hex Key</td> <td>1/2" Socket</td> </tr> </table>	9/16" Wrench	9/16" Socket	3/4" Wrench	3/4" Socket	5/16" Hex Key	1/2" Socket
9/16" Wrench	9/16" Socket							
3/4" Wrench	3/4" Socket							
5/16" Hex Key	1/2" Socket							

Helpful videos:



Assembly Time
Lapse video



Assembly Video
with detail

1



- (3) AW-9044 Trailing Arm Kit
- (3) AA-1081 24" Modbar
- (1) 2" square tube toolbar



- 9/16" Wrench
- 9/16" Socket
- 5/16" Hex Key

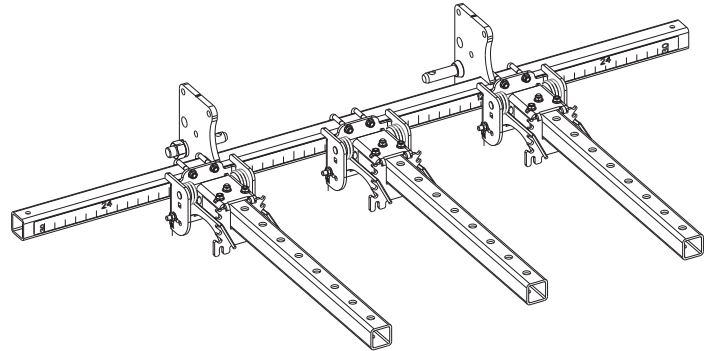

Trailing Arm Kit
Installation pdf

Recommended: Install Trailing Arm Kits and Modbars directly above crop rows. If the toolbar weldments interfere with Trailing Arm Kit placement, connect the trailing arm beside the weldment, and offset the cross-tubes in Step 4.

2



- (4) AA-9049 Flex Tine Mount
- (4) AA-9048 2" Clamp for S-Tine



- 3/4" Wrench
- 3/4" Socket

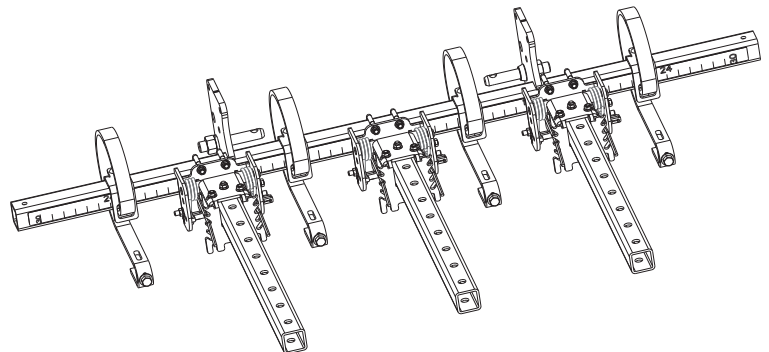

Recommended: Don't fully tighten S-Tine Clamp onto the toolbar until step 5.

continued on back...

3



- (4) A-Blades
- (2) 49-4072 Hardware Pack for Flat/Round Shanks



- 3/4" Wrench or 3/4" Socket
- 9/16" Wrench or 9/16" Socket

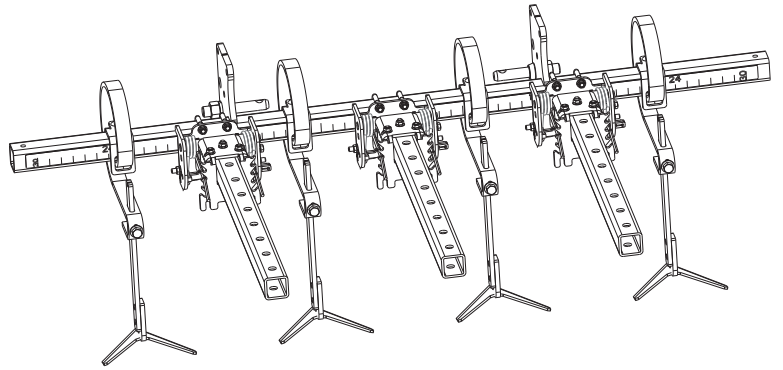

4



- (3) AA-1080 18" Modbar
- (3) AA-9029 2" Square Tube Cross Clamp



- 5/16" Hex Key
- 9/16" Wrench



Modbar and Cross Clamp pdf

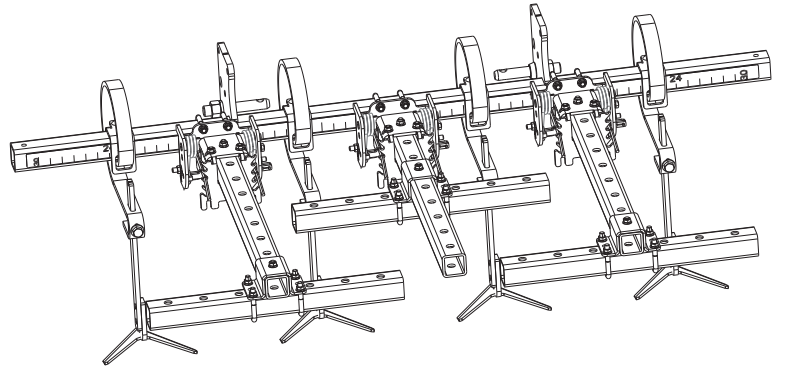

5



- (6) Finger Weeders
- (6) Flat Shanks
- (6) AA-9005 Flat Shank Clamp Assembly



- 3/4" Wrench
- 1/2" Socket
- 9/16" Socket



Finger Weeder assembly pdf

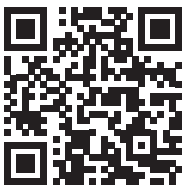
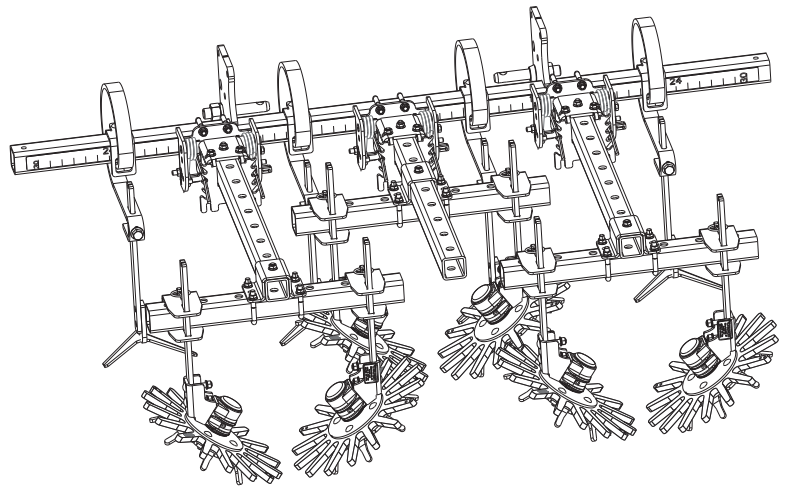

Fine Tuning Instructional video