

Go to www.tilmor.com/resources for complete parts list, additional resources and replacement part ordering.

Release Date: 01/06/2021
Document Number: 12-70039
Revision Number: 03

ATTENTION
Review safety information before operation.



Tools	
	1/2" Socket 9/16" Socket Drive Extension

Installation Time (estimated)

15 minutes

ASSEMBLY

 1/2" Socket, Drive Extension

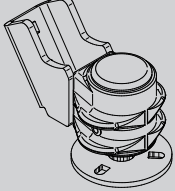
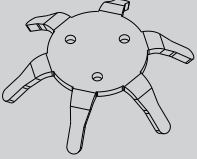
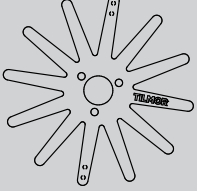

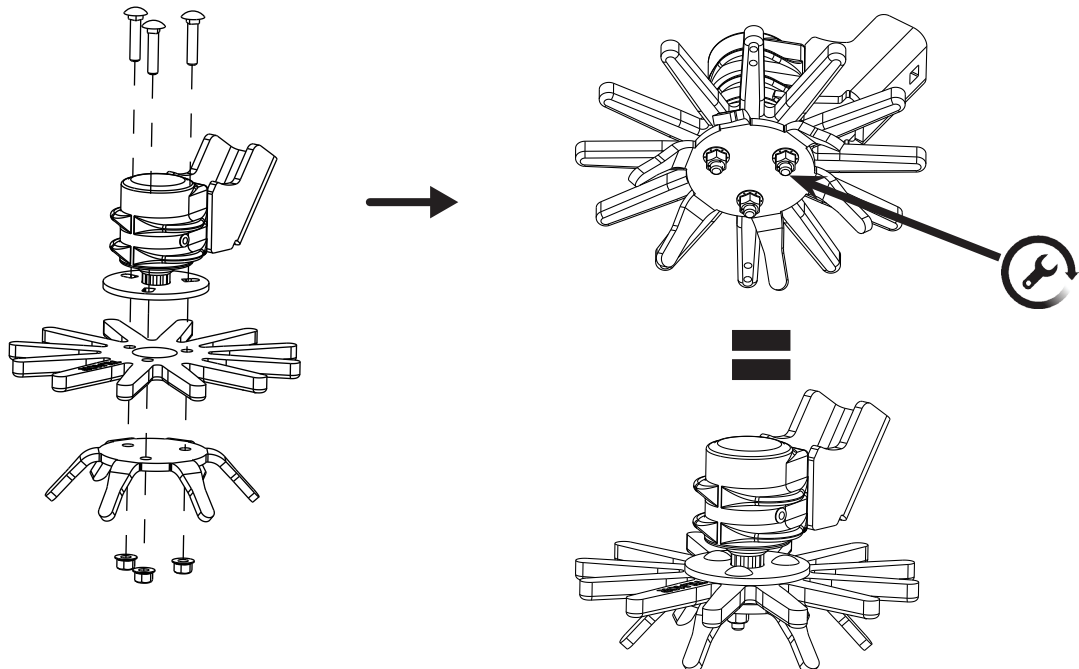
				
3x Bolt, Carriage 5/16" x 1-1/2" 97-0512	3x Nut, Locking Flange 5/16" 99-E0102	1x Hub Assembly	1x Drive Plate AW-1331	1x Finger, Medium 9" (Yellow) AW-3057



- ⚠ Finger Tips:**
- Tighten nuts until drive plate is snug but not indenting the poly finger wheel
 - During off-season, remove drive plate and flip the poly finger before re-assembling

INSTALLATION ON FLAT SHANK

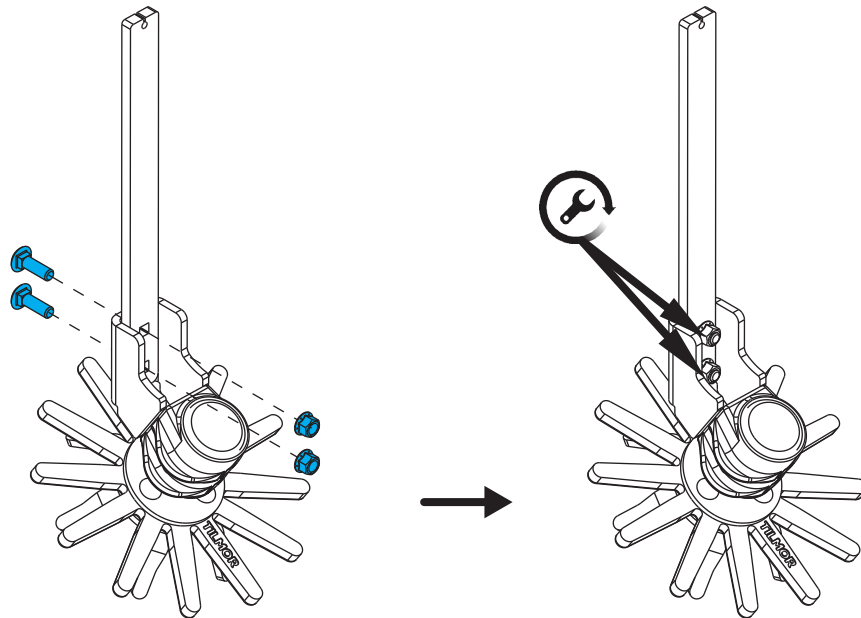

 9/16" Socket

	
2x Bolt, Carriage 3/8" x 1-1/4" 97-0610	2x Nut, Locking Flange 3/8" 99-E0082



INSTALLATION ON MODBAR

 9/16" Socket

	
2x Bolt, Carriage 3/8" x 2-1/4" 97-0618	2x Nut, Locking Flange 3/8" 99-E0082

